

1:1 air operated pump

Single action fluid pump

Models 4475 and 4480 series "A"

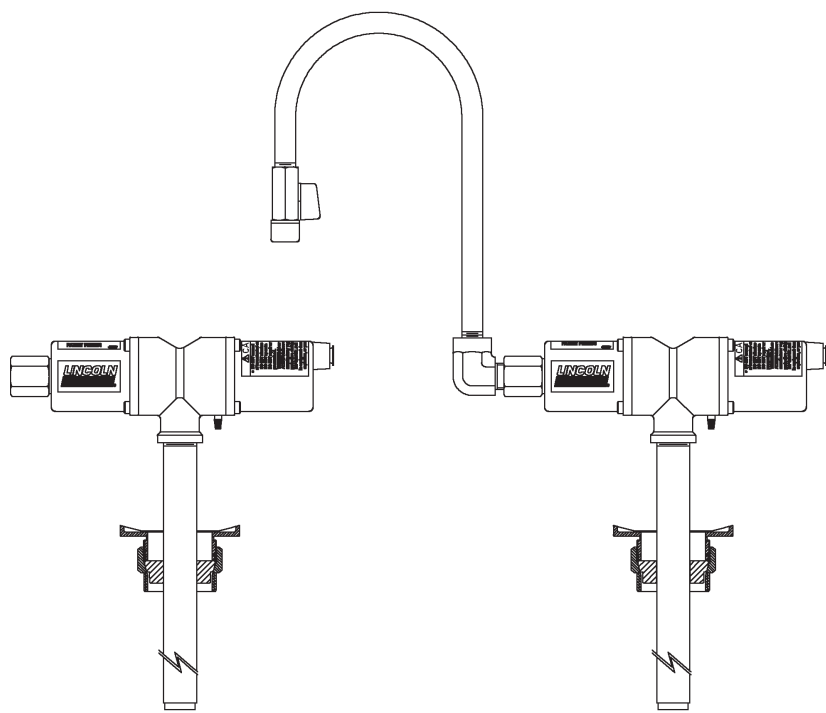

Model 4475

Model 4480

U.S. Patent 6,923,348

This pump conforms to the European Machinery Directive for product safety

Version	05
Date of issue	May 2012
Form number	404430
Section	B5
Page	31D

Table of Contents

Safety	3
Specification	3
Description	3
Appropriate use	3
Before using pump	3
Installation	4
Spigot applications	4
System applications	6
Pressure relief procedures	6
Repair and service parts	6–9
Troubleshooting	10

Safety

Read and carefully observe these operating instructions before operating the air pump. The pump must be operated, maintained and repaired exclusively by persons familiar with the operation instructions.

Adequate personal protection, especially eye protection, is recommended to prevent splashing of material on the skin or in the eyes.

Always disconnect air coupler from pump when the pump is not being used.



Note!

Emphasizes useful hints and recommendations as well as information for efficient and trouble-free operation.



CAUTION

Signalises a dangerous situation, which can lead to light personal injury or property damage, if the precautionary measures are ignored.



Notice!

Signalizes a dangerous situation, which can lead to property damage, if the precautionary measures are ignored.



DANGER

Signalises a dangerous situation, which can lead to death or severe personal injury, if the precautionary measures are ignored.

⚠ WARNING

If any fluid appears to penetrate the skin, get emergency medical immediately. Do not treat injury as a simple cut. Tell attending physician exactly what fluid was injected.

Description

Models 4475 and 4480 are air operated single acting pumps for dispensing low and medium velocity fluids from drum or other tank. The pumps are self priming. Model 4480 pump is supplied with a spigot tube and 1/4 turn dispensing valve to transfer fluid into a manageable container such as a 5 quart can. All models have a 36 in. (914 mm) suction tube with a foot valve to maintain prime.

Appropriate use

Before using pump

The pump was designed to pump the low and medium viscosity fluids using compressed air. The maximum specification rating should not be exceeded.

! Notice!

Do not allow pump to operate when out of material. The pump may be damaged as a result.

! Notice!

Do not use the pump to dispense windshield washer fluids. Pump can seize due to dried fluid.

Specifications

Pump ratio (max)	1:1
Output per stroke	2.9 in ³ (48 cm ³)
Delivery output	3.1 GPM (11,7 liter) at 90 psig air inlet
Suction head primed pump	9 psig (2,7 meter) vacuum at 90 psig air inlet
Pneumatic inlet pressure	Maximum: 150 psig (10,4 bar), minimum: 40 psig (2,8 bar)
Operating temperature range	0 to 120 °F (-18 to +50 °C)
Weight (empty)	4.5 Lbs. (2,0 kg)
Pneumatic port inlet	1/4-18 NPTF
Material port outlet	3/8 or 1/2 NPTF
Recommended Fluids	Mineral and synthetic motor oil, antifreeze, transmission fluid.

⚠ WARNING

Failure to heed the following safety precautions concerning misuse, over pressurizing, modifying parts, using incompatible chemicals and fluids, or using worn or damaged parts, may result in equipment damage and/or serious injury, death, fire, explosion, or property damage.

- Do not exceed the stated maximum working pressure of the pump or of the lowest rated component in your system.
- Do not alter or modify any part of this equipment.
- Do not operate this equipment with combustible gas or fuel, gasoline, diesel fuel, kerosene, etc.
- Do not attempt to repair or disassemble the equipment while the system is pressurized.
- Make sure all fluid connections are securely tightened before using this equipment.
- Always read and follow the fluid manufacturer's recommendations regarding fluid compatibility, and the use of protective clothing and equipment.
- Check all equipment regularly and repair or replace worn or damaged parts immediately.
- Never point the dispensing valve at any part of the body or at another person.
- Never try to stop or deflect material from dispensing valve or leading connection or component with your hand or body.
- Always check equipment for proper operation before each use, making sure safety devices are in place and operating properly.
- Always follow the pressure relief procedure after shutting off the pump, when checking or servicing any part of the system, and when installing, cleaning or changing any part of the system.

Installation

Typical bulk tank and drum system hookups are shown and described as follows only as a guide in selecting and installing a system. Contact a Lincoln factory representative for assistance in designing a system for a specific requirement.

Lincoln recommends using Mini-regulator 602003 (1/4 in. [6 mm] port size) with Gage 247843 and 1/4 in. (6 mm) I.D. Air line supply. (→ Fig. 3, page 7)

! Notice!

The pump was tested in light-weight oil which was left in to protect the pump from corrosion. Flush the pump before connecting it to the system to prevent possible contamination of the fluid you are pumping.

Clean/flush the supply lines, hoses, reducers, connectors and accessories with mineral spirits or oil based solvent to purge any contaminants such as dirt, moisture, or metal shavings that could damage the pump or system components. Blow dry with air.

⚠ WARNING

To reduce the risk of injury from splashing or static sparking when flushing the pump with solvents, always hold a metal part of the dispensing valve firmly to the side of a grounded metal pail and operate at lowest possible fluid pressure.

Spigot applications

Make sure all connections are tight. Thread the pump tube into the 3/4 in. NPT material inlet of the pump as shown in Fig. 1, page 5.

Loosen the bung collet and install the bung bushing into the 2 in. NPT fitting of your drum or tank. Slide the pump and pump tube into the bung collet and adjust to desired height. Make sure all connections are securely tightened.

To start pump in spigot applications, turn on the main air supply. Slowly open the air regulator. Regulate air pressure from 20–40 psig (1,3–2,8 bar). Open the dispensing valve 1/4 turn to allow air to be purged from the system. Allow pump to cycle until fluid without air pockets flows from dispensing valve, then close dispensing valve.

In a direct supply system, with adequate air pressure supplied to the motor, the pump starts when the 1/4 turn dispensing valve is opened and stalls against pressure when it is closed.

! Note!

Important: the pump will lose prime without the foot valve. Contact Lincoln technical service for any modification of the tube .

Typical spigot application

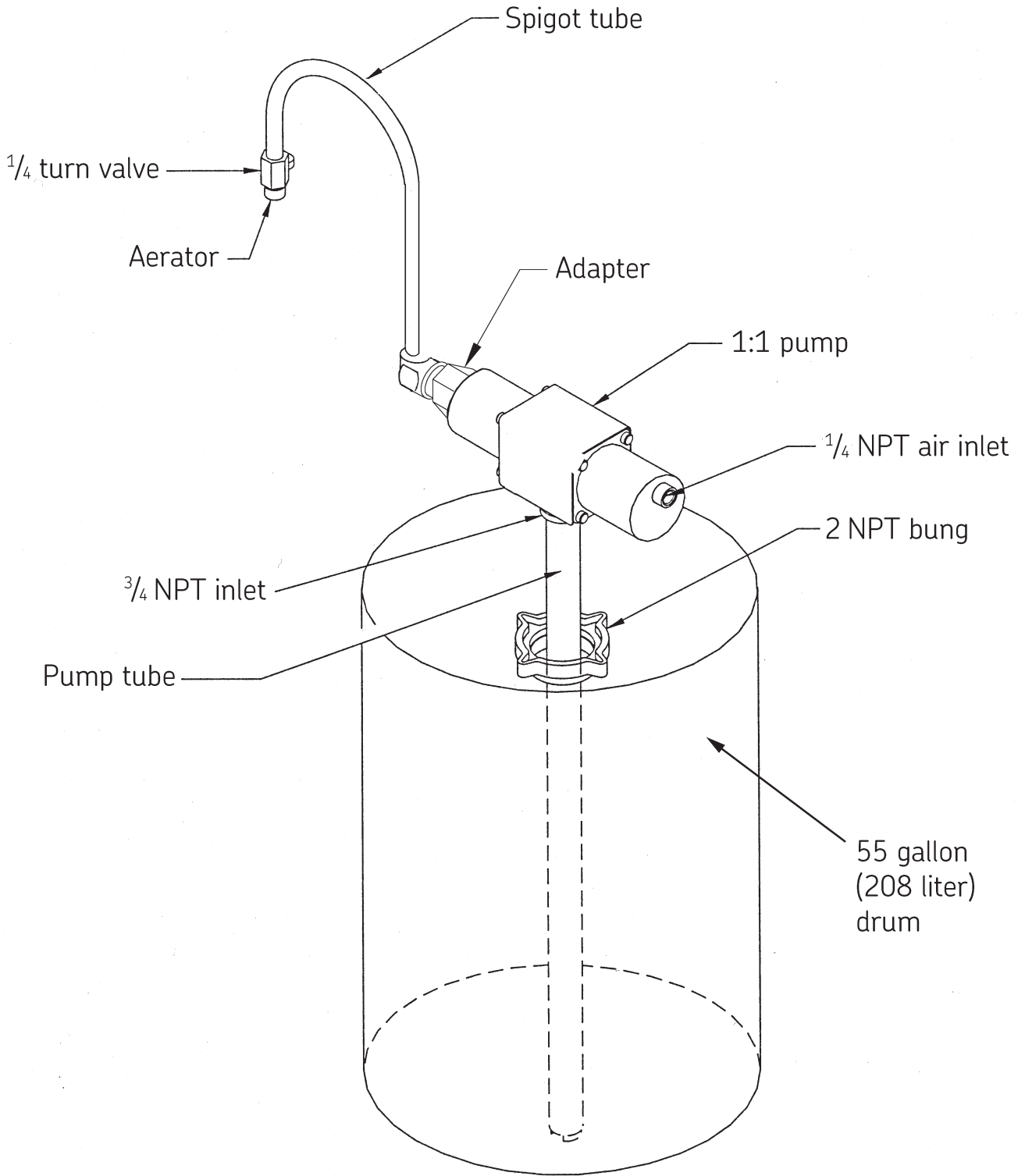

System application

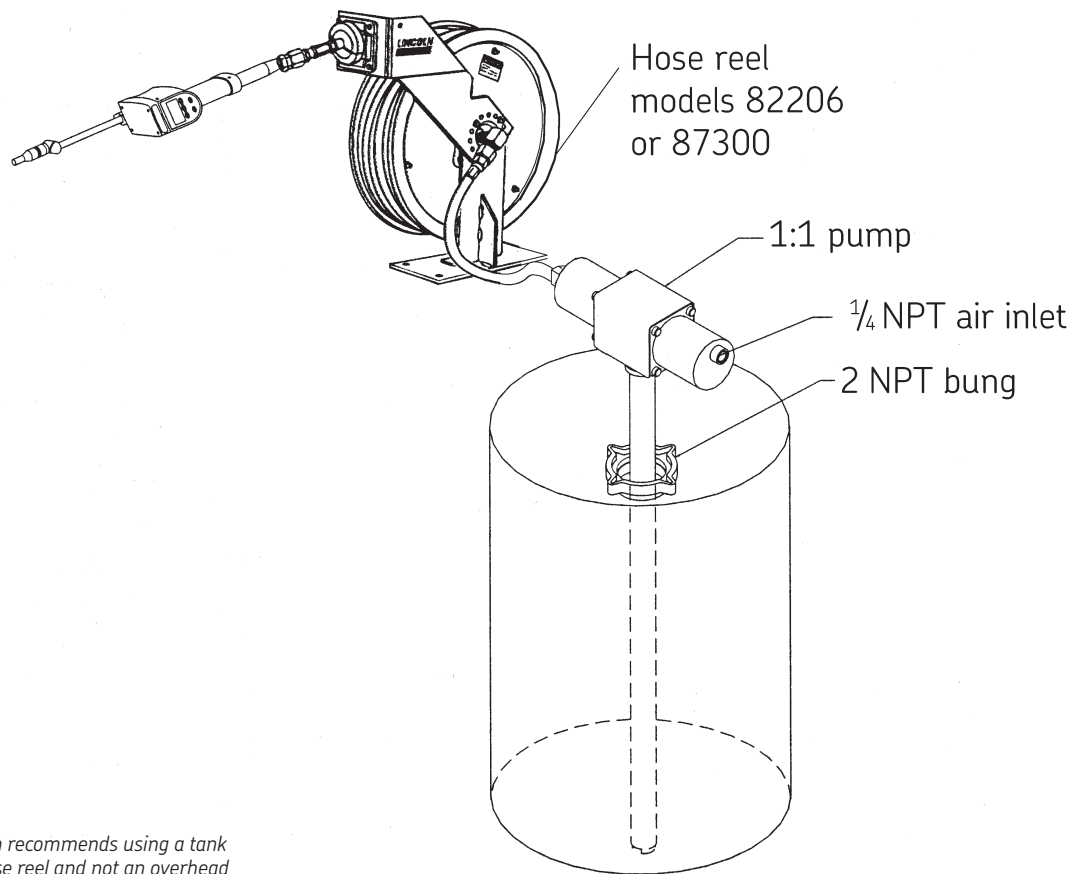

Note: Lincoln recommends using a tank mounted hose reel and not an overhead mounted reel.

System applications

To start the pump in a system application, air must be purged from the system before installing. Connect the pump outlet to a short 1/2 in. NPT hose. Turn on the main air supply, and slowly open the air regulator. Regulate the air pressure from 20–40 psig (1,3–2,8 bar). Allow the pump to cycle until fluid without air pockets flows from the outlet hose. Disconnect the outlet hose and connect the primed pump to the system, as shown in **fig. 2**.

Pressure relief procedure

Always perform this procedure when the pump is shut off and before checking, servicing, installing, cleaning or repairing any part of this system.

Perform the following procedure:

- 1 Close the dispensing valve 1/4 turn.
- 2 Disconnect air supply to the pump.
- 3 Point dispensing valve away from yourself and others.
- 4 Open the dispensing valve into an appropriate container until the pressure is relieved.

If the above procedure does not relieve the pressure, the dispensing valve or hose may be restricted. To relieve the pressure, very slowly loosen the aerator from the 1/4 turn dispensing valve. Then loosen completely and clear the dispensing valve.

Repair

Repair is limited to replacement of listed service parts. Special procedures and tools are required. Contact Lincoln customer service, One Lincoln Way, St. Louis, MO 63120-1578, (314) 679-4200 for your nearest authorized service center.

When ordering replacement parts, list: part number, description, model number and series letter.

Annual inspection by a factory authorized service center is recommended.

Fig. 3

Air regulator model 602003 with pressure gauge model 247843

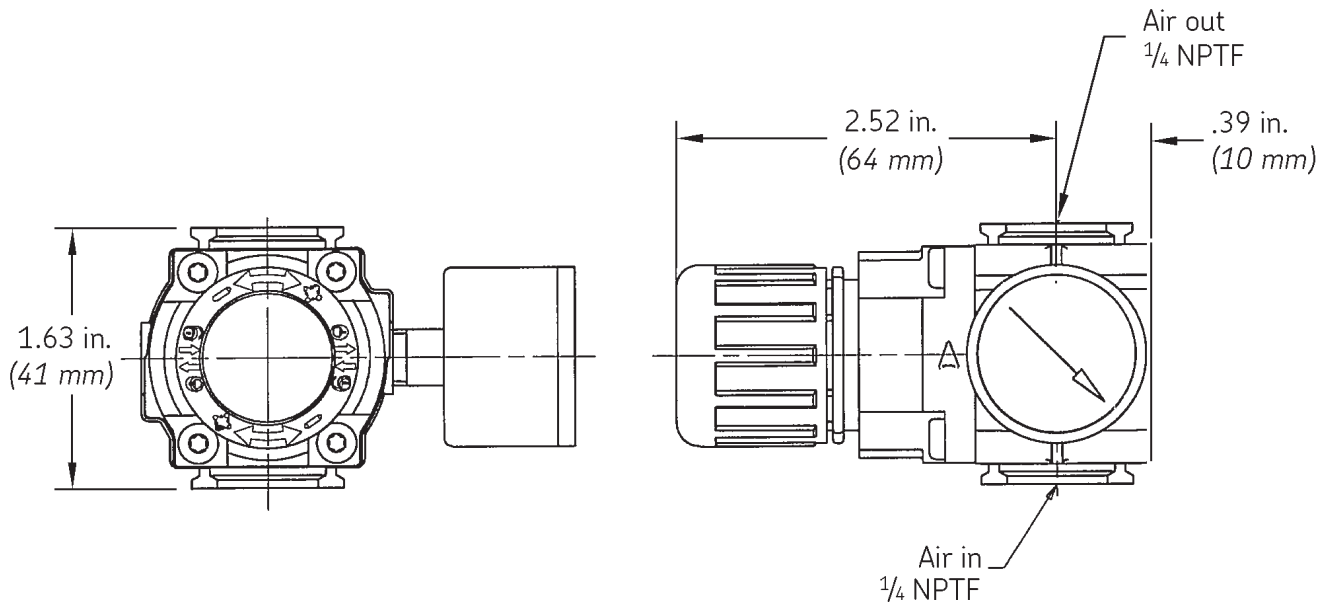
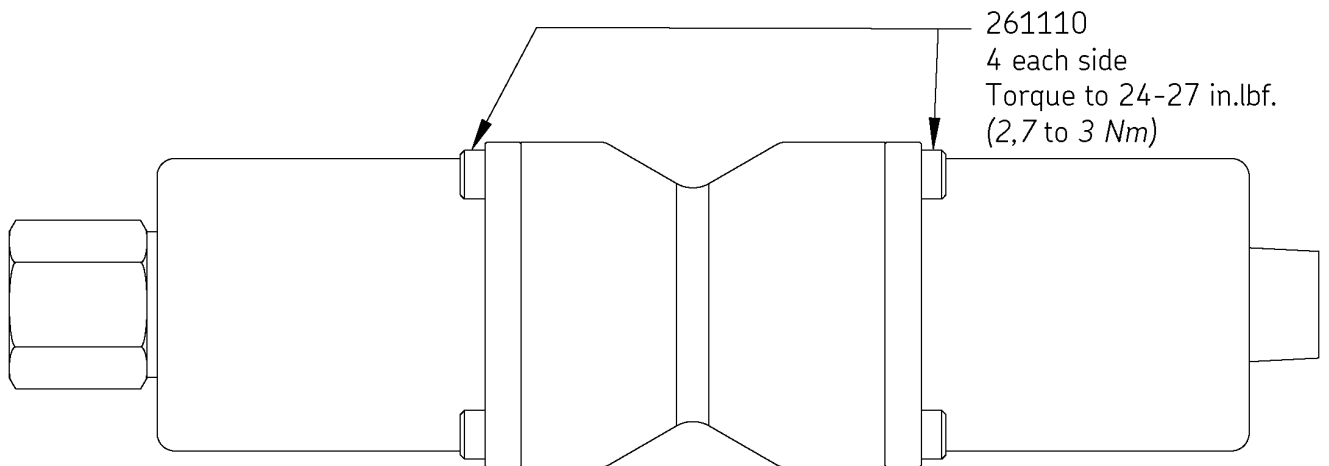
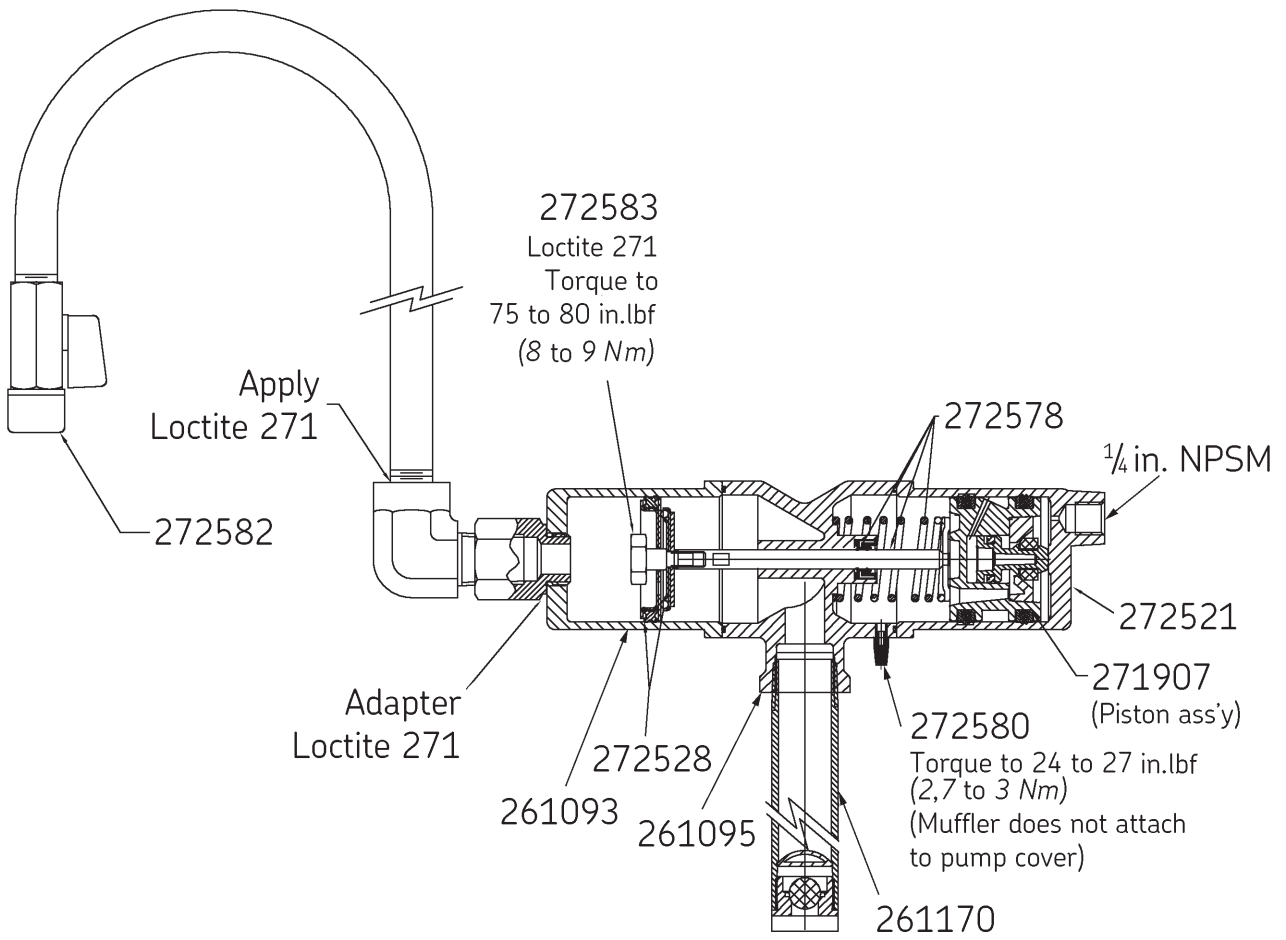

Fig. 4





Service parts

Part no.	Description	Includes	Qty
272528	Kit, seal	Ring, quad 2 in. OD x 1 5/8 in. (51 mm OD x 41 mm) O-ring, 2.114 x 0.070 in. (54 x 2 mm) Seal, rod 5/16 in. ID x 5/8 in. OD (8 mm ID x 16 mm OD) O-ring 1 1/4 in. ID x 1/8 in buna (32 mm ID x 3 mm buna)	1 1 1 1
272578	Kit, spring	Ring, quad 2 in. OD x 1 5/8 in. (51 mm OD x 41 mm) Seal, rod 5/16 in. ID x 9/16 in. (8 mm ID x 14 mm) O-ring, 2.114 in. x 0.070 in. (54 x 2 mm) Spring, piston Piston, rod assembly O-ring 1 1/4 in. ID x 1/8 in. buna (32 mm ID x 3 mm buna)	1 1 1 1 1 1
272583	Kit, oil piston	Washer, back-up Seal, weldment Weldment, quad ring O-ring, 2.114 in. x 0.070 in. (54 x 2 mm) Bolt, pump rod O-ring 1 1/4 in. ID x 1/8 in. buna (32 mm ID x 3 mm buna)	1 1 1 1 1 1
272580	Kit, muffler	Muffler sintered bronze	1
272581	Kit, air piston	Piston assembly	1
272582	Kit, spigot	Spigot tube Valve, 1/4 turn Ell, 1/2 NPT x 3/8 NPT Aerator/Adapter ass'y	1 1 1 1
261170	Pump tube ass'y	Tube Seat, check Stop, ball Ball	1 1 1 1
261093	Housing, pump piston	Housing , pump piston	1
261095	Machined pump head	Machined pump head	1
272521	Housing, air piston	Machined pump head	1
602003	Mini-regulator	Mini-regulator	1
261110	Screw	Screw	8

Troubleshooting

Conditions	Possible cause	Corrective action
The pump doesn't operate	No inlet air pressure The piston is stuck.	Connect air supply. Disassemble the pump inspect for damage, relubricate. Replace if necessary Check air pressure supply. The pressure is to be higher 20 psig (1,4 bar). Replace if necessary.
	Air pressure is too low.	
	Broken return spring	
The pump cycles but doesn't deliver fluid.	Loss of prime The container is out of liquid The ball check valve is not functioning.	Repeat priming operation Check that container has fluid. Disassemble check valve, remove ball, clean and inspect ball seat area.
The pump still doesn't operate		Contact an authorized service center.

Declaration of conformity as defined by machinery directive 2006/42/EC Annex II A

This is to declare that the design of the Single Action 1:1 Air Operated Pumps (models 4475 and 4480) complies with the provisions of Directive 98/37/EG

Applied standards:

- EN 292-1 Safety of machinery – Basic concepts, general principles and design – part 1: basic terminology, methodology
- EN 292-2 Safety of machinery – Basic concepts, general principles and design – part 2: technical principles and specifications – Incorporates amendments 1 (1995) and 2 (1997)
- EN 809 Pumps and pump units for liquids – common safety requirements
- EN 349 Safety of machinery – minimum gaps to avoid crushing of parts of the human body

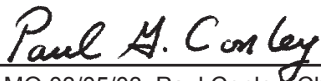

St. Louis, MO 03/05/03, Paul Conley, Chief Engineer

Lincoln industrial standard warranty

Standard Limited warranty

Lincoln warrants the equipment manufactured and supplied by Lincoln to be free from defects in material and workmanship for a period of one (1) year following the date of purchase, excluding there from any special, extended, or limited warranty published by Lincoln. If equipment is determined to be defective during this warranty period, it will be repaired or replaced, within Lincoln's sole discretion, without charge.

This warranty is conditioned upon the determination of a Lincoln authorized representative that the equipment is defective. To obtain repair or replacement, you must ship the equipment, transportation charges prepaid, with proof of purchase to a Lincoln Authorized Warranty and Service Center within the warranty period.

This warranty is extended to the original retail purchaser only. This warranty does not apply to equipment damaged from accident, overload, abuse, misuse, negligence, faulty installation or abrasive or corrosive material, equipment that has been altered, or equipment repaired by anyone not authorized by Lincoln. This warranty applies only to equipment installed, operated and maintained in strict accordance with the written specifications and recommendations provided by Lincoln or its authorized field personnel.

This warranty is exclusive and is in lieu of any other warranties, express or implied, including, but not limited to, the warranty of merchantability or warranty of fitness for a particular purpose. Warranty on items sold by Lincoln, but not manufactured by Lincoln are subject to the warranty consideration, if any, of their manufacturer (such as hoses, hydraulic and electric motors, electrical controllers, etc.) Assistance in making such warranty claims can be offered as required.

In no event shall Lincoln be liable for incidental or consequential damages. Lincoln's liability for any claim for loss or damages arising out of the sale, resale or use of any Lincoln equipment shall in no event exceed the purchase price. Some jurisdictions do not allow the exclusion or limitation of incidental or consequential damages, therefore the above limitation or exclusion may not apply to you.

This warranty gives you specific legal rights. You may also have other rights that vary by jurisdiction.

Customers not located in the Western Hemisphere or East Asia: Please contact Lincoln GmbH and Co. Kg, Walldorf, Germany, for your warranty rights.

Special limited warranties

Special limited 2 year warranty sl-v series, single injectors-85772, 85782, and replacement injectors-85771, 85781

Lincoln warrants the SL-V Injector series to be free from defects in material and workmanship for two (2) years following the date of purchase. If an injector model (single or replacement) is determined to be defective by Lincoln, in its sole discretion, during this warranty period, it will be repaired or replaced, at Lincoln's discretion, without charge.

Special limited 5 year warranty series 20, 25, 40 bare pumps, pmv bare pumps, heavy duty and 94000 series bare reels

Lincoln warrants series 20, 25, 40 bare pumps, PMV bare pumps, Heavy Duty (82206), Mini Bench (81133, 81323), and all 94000 LFR series (single arm and dual arm) bare reels to be free from defects in material and workmanship for five (5) years following the date of purchase. If equipment is determined by Lincoln, in its sole discretion, to be defective during the first year of the warranty period, it will be repaired or replaced at Lincoln's discretion, without charge. In years two (2) and three (3), the warranty on this equipment is limited to repair with Lincoln paying parts and labor only. In years four (4) and five (5), the warranty on this equipment is limited to repair with Lincoln paying for parts only.

Special limited 5 year warranty-limited oil meters, limited fluid control valves, aod (air-operated diaphragm pumps)

Lincoln warrants the 712 series Control Valves, 912 series Lube Meters, Electronic Lube Meters (980, 981, 982 series), our Universal Inline Digital Meters (812/813 series), and our AOD Pump offering to be free from defects in material and workmanship for five (5) years following the date of purchase. If either is determined to be defective by Lincoln, in its sole discretion, during the warranty period, they will be repaired or replaced, at Lincoln's discretion, without charge.

Special DEF (diesel exhaust fluid) limited warranty

DEF products are warranted to be free from defects in material and workmanship for a period of one (1) year following the date of purchase. The following exceptions to the standard warranty period are in effect

- **85700-30/85700-50 DEF hose reels (bare reel only),** 277251/277252 AC DEF pumps, and 277256 and 277257 DEF meters are warranted for two (2) years from date of purchase,
- **85623 DEF AOD (air operated diaphragm) pumps** are covered under the standard five (5) year AOD pump warranty.

If either is determined to be defective by Lincoln, in its sole discretion, during the warranty period, they will be repaired or replaced, at Lincoln's discretion, without charge.

Lincoln Industrial contact information

To find Lincoln Industrial's Nearest Service Center call one of the following numbers, you may also use our website
Customer Service 314-679-4200
Website lincolnindustrial.com

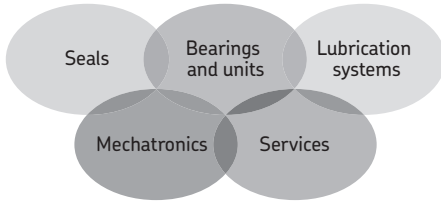

The Power of Knowledge Engineering

Drawing on five areas of competence and application-specific expertise amassed over more than 100 years, SKF brings innovative solutions to OEMs and production facilities in every major industry worldwide. These five competence areas include bearings and units, seals, lubrication systems, mechatronics (combining mechanics and electronics into intelligent systems), and a wide range of services, from 3-D computer modelling to advanced condition monitoring and reliability and asset management systems. A global presence provides SKF customers uniform quality standards and worldwide product availability.

© SKF is a registered trademark of the SKF Group.

© Lincoln is a registered trademark of Lincoln Industrial Corp.

© SKF Group 2012

The contents of this publication are the copyright of the publisher and may not be reproduced (even extracts) unless prior written permission is granted. Every care has been taken to ensure the accuracy of the information contained in this publication but no liability can be accepted for any loss or damage whether direct, indirect or consequential arising out of the use of the information contained herein.

SKF PUB LS/11 12930 XX.XX · May 2012 · Form 404430

Printed in USA on environmentally friendly paper.

