

MODEL  
1385

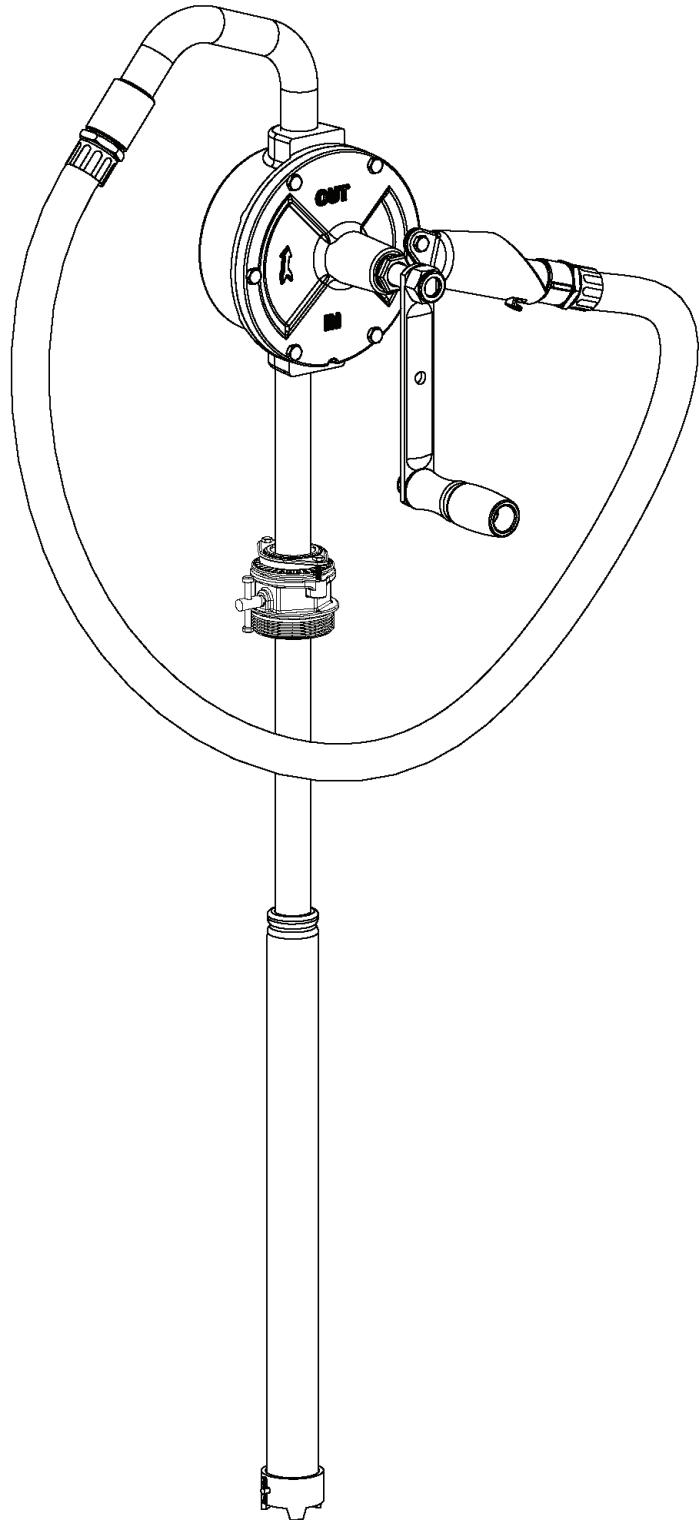

MODEL  
1385-H

# MODEL 1385 & 1385-H Professional Rotary Drum Pump



## OWNER/OPERATOR RESPONSIBILITY

All instructions and warnings contained in this manual shall be read and understood by the owner/operator prior to operating this equipment.

It is the owner/operator responsibility to maintain the legibility of all warning and instruction labels.

The owner/operator shall retain this manual for future reference to important warnings, operating and maintenance instructions.

## DESCRIPTION

Fluid transfer pump for use with oil-based fluids, heating oils, motor oils, heavy & light oils, ATF, diesel, kerosene & anti-freeze.

**NOT SUITABLE FOR USE WITH GASOLINE, WATER BASED FLUIDS (i.e. windshield washer fluid), SOLVENTS, NOR ACIDS.**

The outlet discharge spout is thread size  $\frac{3}{4}$ -11 $\frac{1}{2}$  AN. This is the common thread found on most aftermarket hoses.

## PRODUCT BRIEF

- Easy installation
- Extremely durable cast iron design, low-wear graphite three-vane impellers, high-strength precision fit grip
- Exceptional vacuum eliminates the need to prime pump
- Delivers fluid without the excessive splash common to other rotary designs
- 1385-H contains an 8 foot hose, dispense nozzle and hose holder
- Provides the portability and convenience of a manual design
- Excellent for demanding markets such as agriculture, construction, industrial and large service facilities
- Includes 2" male NPT bung adapter and telescopic pick-up tube to fit 16-55 gallon container depths with 2" bung
- Fully servicable

## INSTALLATION AND ASSEMBLY

- 1) Slide the bung onto the top portion of the suction tube. Do not tighten.
- 2) Wrap the male suction tube threads with teflon tape or equivalent. Thread the suction tube into the inlet side of pump. (see marking on pump) tighten securely.
- 3) Extend the pick-up tube and place it into the drum's 2" bung opening.
- 4) Thread the bung bushing into the tank and tighten it securely.
- 5) Position the pump head at the desired height and angle and tighten the bung side bolt.  
**NOTE:** if the pump position is too high the pick-up tube cannot capture fluid below the intake base.
- 6) Wrap the discharge spout threads with teflon tape or equivalent. Thread the discharge spout onto the output side of pump.

- 7) Attach the pump handle onto the pump shaft and secure with the hex nut. (torque to 40 ft-lbs)
- 8) On the model 1385-H; securely attach the die-cast dispensing nozzle to the end of hose after wrapping with teflon tape or equivalent.
- 9) Securely attach the other end of hose to outlet tube after wrapping with teflon tape or equivalent.
- 10) Attach the die-cast hose holder to the side of the pump by removing the cover bolt shown on the nozzle holder detail. Tilt the holder about 30° to prevent the loss of any fluid remaining in hose during use.
- 11) Retighten the bolt to secure into position. (torque to 50 in-lbs/4 ft. lbs.)

## ATTENTION

- Wear protective eyewear and clothing.
- Do not smoke near the pump.
- Do not use near fire or flame
- Store in a well ventilated area



## WETTED COMPONENTS

Cast Iron, Steel, Graphite, Paper Gasket, Polypropylene.

## SPECIFICATIONS:

Maximum viscosity – SAE 140  
Maximum fluid temperature: 250°F / 120°C  
Output: 10 gallons (38L) per minute @ 120 RPM  
Output per revolution: .35QTS / .33L  
Mounting: 2 Inch NPT (M)  
Adjustable suction tube length: 18" (46 cm) to 34.5" (87.5 cm)

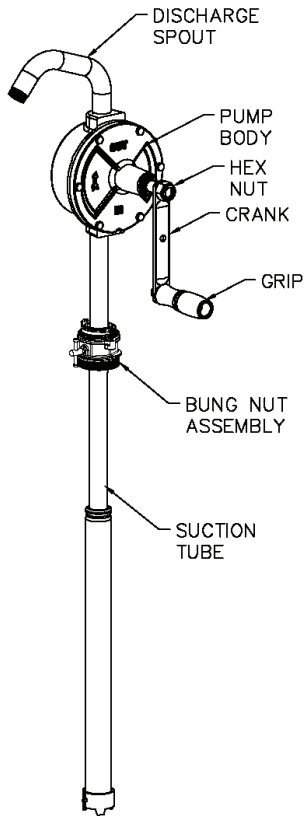

MODEL  
1385

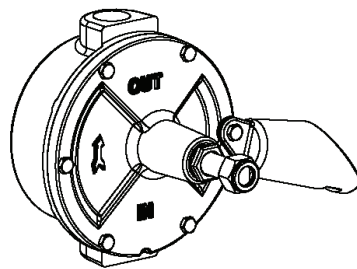

NOZZLE  
HOLDER  
DETAIL

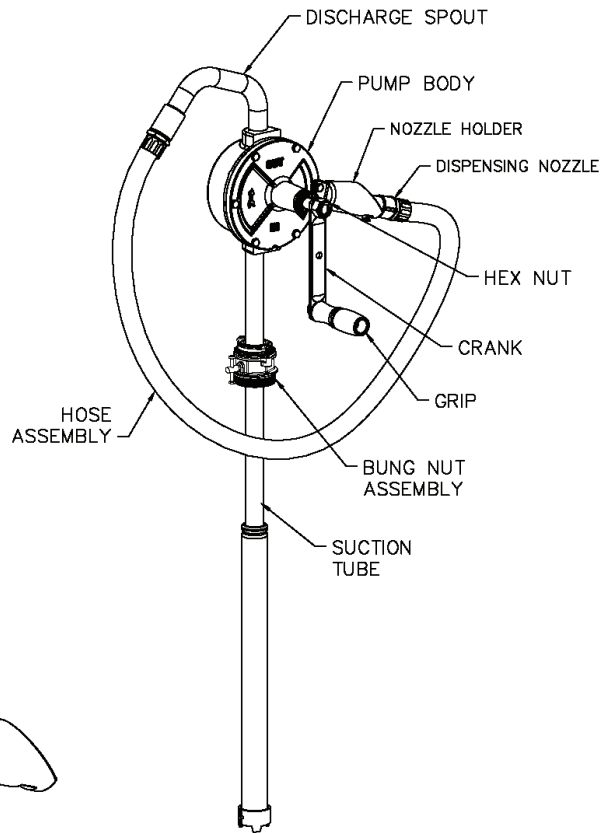

MODEL  
1385-H

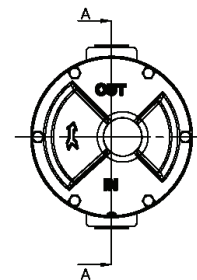
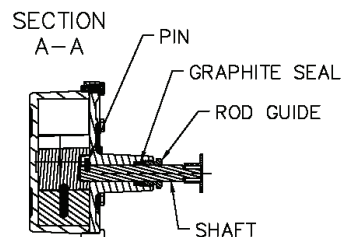
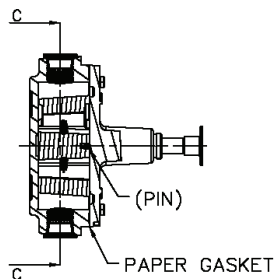
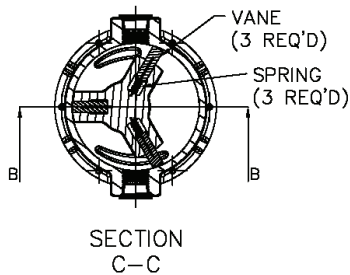

**MODEL 1385 & 1385-H**  
**Professional Rotary Drum Pump**



MODEL	1385	1385-H
SUCTION TUBE	277188	277188
HANDLE ASSEMBLY		
GRIP CRANK HEX NUT	277189	277189
BUNG NUT ASSEMBLY	277191	277191
HOSE ASSEMBLY	N/A	277193
VANE REPAIR KIT		
VANE (3 REQ'D) VANE SPRING PAPER GASKET	277202	277202
DRIVE SHAFT REPAIR KIT		
SHAFT GRAPHITE SEAL ROD GUIDE SHAFT PIN	277190	277190
ACCESSORY KIT	277199	277200
DISCHARGE SPOUT	*	*
HEX NUT FOR HANDLE	*	*
DISPENSING NOZZLE		*
NOZZLE HOLDER		*
COUPLER		*

\*INCLUDED IN ACCESSORY KITS LISTED  
DIRECTLY ABOVE

### TROUBLE SHOOTING

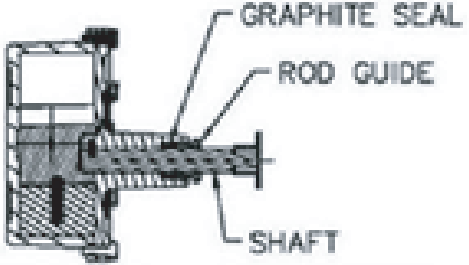
SYMPTOM	PROBABLE CAUSE	CORRECTIVE ACTION
<b>Pump fails to move fluid</b>	1. Pick-up tube not extended into fluid.	Verify tube is extended below the fluid depth in drum.
	2. Poor seal between suction tube and pump.	Reapply teflon tape to the male suction tube threads and tighten securely.
	3. Debris in pump vanes.	Remove handle and cover plate, remove any debris, check for worn or scored components. Replace as necessary.
<b>Low flow rate</b>	1. Poor seal between suction tube and pump.	Reapply teflon tape to the male suction tube threads and tighten securely.
	2. Debris in pump or pump tube, discharge spout or hose	Remove handle and cover plate, remove any debris. Clean hose, pick-up tube and/or discharge spout.
	3. Worn internal parts	Remove handle and cover plate, remove any debris, check for worn or scored components. Replace as necessary.
	4. Kinked or damaged hose	Replace hose.
<b>Pump seized or handle turns hard</b>	1. Debris in pump or pump tube.	Remove handle and cover plate, remove any debris. Clean pick-up tube.
	2. Pump rusted or components swelled or damaged from improper fluid use.	Check for housing rust, worn or swollen seals. Replace as necessary.
<b>Leaking from rod guide</b>	1. Rod guide needs adjustment	<p>Using 1" wrench, tighten the rod guide in 1/4 inch increments in clockwise direction.</p> <p>Rotate the shaft by handle and check for leakage.</p> <p>Repeat step 1 if leakage is found.</p> <p>Repeat step 1 and 2 until leakage is stopped.</p> 

# MODEL 1385 & 1385-H Professional Rotary Drum Pump



## Lincoln Industrial Standard Warranty

### LIMITED WARRANTY

Lincoln warrants the equipment manufactured and supplied by Lincoln to be free from defects in material and workmanship for a period of one (1) year following the date of purchase, excluding therefrom any special, extended, or limited warranty published by Lincoln. If equipment is determined to be defective during this warranty period, it will be repaired or replaced, within Lincoln's sole discretion, without charge.

This warranty is conditioned upon the determination of a Lincoln authorized representative that the equipment is defective. To obtain repair or replacement, you must ship the equipment, transportation charges prepaid, with proof of purchase to a Lincoln Authorized Warranty and Service Center within the warranty period.

This warranty is extended to the original retail purchaser only. This warranty does not apply to equipment damaged from accident, overload, abuse, misuse, negligence, faulty installation or abrasive or corrosive material, equipment that has been altered, or equipment repaired by anyone not authorized by Lincoln. This warranty applies only to equipment installed, operated and maintained in strict accordance with the written specifications and recommendations provided by Lincoln or its authorized field personnel.

**THIS WARRANTY IS EXCLUSIVE AND IS IN LIEU OF ANY OTHER WARRANTIES, EXPRESS OR IMPLIED, INCLUDING, BUT NOT LIMITED TO, THE WARRANTY OF MERCHANTABILITY OR WARRANTY OF FITNESS FOR A PARTICULAR PURPOSE.**

In no event shall Lincoln be liable for incidental or consequential damages. Lincoln's liability for any claim for loss or damages arising out of the sale, resale or use of any Lincoln equipment shall in no event exceed the purchase price. Some jurisdictions do not allow the exclusion or limitation of incidental or consequential damages, therefore the above limitation or exclusion may not apply to you.

This warranty gives you specific legal rights. You may also have other rights that vary by jurisdiction.

Customers not located in the Western Hemisphere or East Asia: Please contact Lincoln GmbH & Co. KG, Walldorf, Germany, for your warranty rights.

### Lincoln Industrial Special Limited Warranties

#### SPECIAL LIMITED 2 YEAR WARRANTY-

##### SL-V Series, Single Injectors-85772, 85782, and Replacement Injectors-85771, 85781

Lincoln warrants the SL-V Injector series to be free from defects in material and workmanship for two (2) years following the date of purchase. If an injector model (single or replacement) is determined to be defective by Lincoln, in its sole discretion, during this warranty period, it will be repaired or replaced, at Lincoln's discretion, without charge.

#### SPECIAL LIMITED 5 YEAR WARRANTY-

##### Series 20, 25, 40 Bare Pumps, PMV Bare Pumps, Heavy Duty and 94000 Series Bare Reels

Lincoln warrants series 20, 25, 40 bare pumps, PMV bare pumps, Heavy Duty (82206), Mini Bench (81133, 81323), and 94000 LFR series (94100, 94300, 94500) bare reels to be free from defects in material and workmanship for five (5) years following the date of purchase. If equipment is determined by Lincoln, in its sole discretion, to be defective during the first year of the warranty period, it will be repaired or replaced at Lincoln's discretion, without charge. In years two (2) and three (3), the warranty on this equipment is limited to repair with Lincoln paying parts and labor only. In years four (4) and five (5), the warranty on this equipment is limited to repair with Lincoln paying for parts only.

#### SPECIAL LIMITED 5 YEAR WARRANTY-

##### LFM Series Oil Meters (Lincoln Fluid Meter), LFV (Lincoln Fluid Valves), AOD (Air-Operated Diaphragm Pumps)-

Lincoln warrants the LFM meter series (908/912 series), the Lincoln Fluid valve (708/712 series), our Universal Inline Digital Meters (812/813 series), and our AOD Pump offering to be free from defects in material and workmanship for five (5) years following the date of purchase. If either is determined to be defective by Lincoln, in its sole discretion, during the warranty period, they will be repaired or replaced, at Lincoln's discretion, without charge.

### Lincoln Industrial Contact Information

To find Lincoln Industrial's Nearest Service Center call the following number, you may also use our website

Customer Service 314-679-4200  
Website lincolnindustrial.com

Americas:  
One Lincoln Way  
St. Louis, MO 63120-1578  
USA  
Phone +1.314.679.4200  
Fax +1.800.424.5359

Europe /Africa/Middle East  
Lincoln GmbH  
Heinrich-Hertz-Str. 2-8  
69190 Walldorf - Germany  
Phone/Fax +49.6227.33-0/-259  
www.lincolnindustrial.de

Asia/Pacific:  
No. 3 Tampines Central 1  
#04-05, Abacus Plaza.  
Singapore 529540  
Tel +65.6588.0188  
Fax +65.6588.3438

© Copyright Lincoln Industrial  
Corporation 2010  
Printed in USA  
Web site:  
www.lincolnindustrial.com