

SERVICE & OPERATING MANUAL



Models 85631, 85632, 85633, 85636 Series B 1/2" Aluminum Air-Operated Double Diaphragm Pump



II 2GD T5

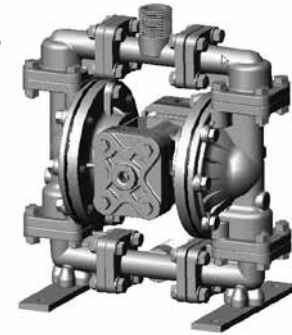
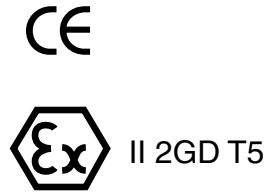

Table of Contents

Engineering Data and Temperature Limitations	1	Composite Repair Parts List for Models 85631, 85632, 85633	11
Performance Curve	2	Composite Repair Parts Drawing for Dual Port Suction Model 85636	12
Dimensions.....	3	Composite Repair Parts List for Dual Port Suction Model 85636.....	13
Dual Port Suction Dimensions.....	4	Air Valve Assembly Drawing and Parts List	14
Principle of Pump Operation.....	5	Air Valve Assembly Servicing	15
Installation and Start-up.....	5	Diaphragm Service Drawing, Non-Overlay.....	16
Air Supply	5	Diaphragm Service Drawing, with Overlay.....	16
Air Valve Lubrication.....	5	Diaphragm Servicing	17
Air Line Moisture.....	5	Overlay Diaphragm Servicing	17
Air Inlet and Priming	5	Pilot Valve Servicing, Assembly Drawing, and Parts List	18
Between Uses	5	Intermediate Assembly Drawing, Parts List and Servicing	19
Installation Guide.....	6	Check Valve Drawing and Servicing.....	20
Troubleshooting	7	Pumping Hazardous Liquids.....	21
Important Safety Information	8	Converting the pump for piping the exhaust air.....	21
Composite Repair Parts Drawing for Models 85631, 85632, 85633	10	Exhaust Conversion Drawing	21
Overlay Option Drawing, Muffler Option Drawing.....	10	Converted Exhaust Illustration.....	21
Available Service and Conversion Kits.....	10	Grounding the Pump	22
		CE Declaration of Conformity	23

Version 2

LINCOLN • One Lincoln Way, St. Louis, MO 63120-1578 • Customer Service (314) 679-4200



Models 85631, 85632, 85633, 85636 Series B

1/2" Aluminum Air-Operated Diaphragm Pump

ENGINEERING, PERFORMANCE
& CONSTRUCTION DATA

INTAKE/DISCHARGE PIPE SIZE 1/2" NPT or 1/2" BSP (Tapered) 1" NPT or 1" BSP (Tapered)	CAPACITY 0 to 15 gallons per minute (0 to 56 liters per minute)	AIR VALVE No-lube, no-stall design	SOLIDS-HANDLING Up to .125 in. (3mm)	HEADS UP TO 125 psi or 289 ft. of water (8.6 Kg/cm ² or 86 meters)	DISPLACEMENT/STROKE .026 Gallon / .098 liter
---	--	---	--	--	--

⚠ CAUTION! Operating temperature limitations are as follows:

Materials

		Operating Temperatures	
		Maximum	Minimum
Buna N	General purpose, oil-resistant. Shows good solvent, oil, water and hydraulic fluid resistance. Should not be used with highly polar solvents like acetone and MEK, ozone, chlorinated hydrocarbons and nitro hydrocarbons.	190°F 88°C	-10°F -23°C
EPDM	Shows very good water and chemical resistance. Has poor resistance to oil and solvents, but is fair in ketones and alcohols.	280°F 138°C	-40°F -40°C
Neoprene	All Purpose. Resistant to vegetable oil. Generally not affected by moderate chemicals, fats, greases and many oils and solvents. Generally attacked by strong oxidizing acids, ketones, esters, nitro hydrocarbons and chlorinated aromatic hydrocarbons.	200°F 93°C	-10°F -23°C
Santoprene®	Injection molded thermoplastic elastomer with no fabric layer. Long mechanical flex life. Excellent abrasion resistance.	275°F 135°C	-40°F -40°C
Virgin PTFE	Chemically inert, virtually impervious. Very few chemicals are known to react chemically with PTFE: molten alkali metals, turbulent liquid or gases fluorine and a few fluoro-chemicals such as chlorine trifluoride or oxygen difluoride which readily liberate free fluorine at elevated temperatures.	220°F 104°C	-35°F -37°C

Performance Curve, Models 85631, 85632, 85633, 85636 Series B

MODEL S05 Metallic Performance Curve

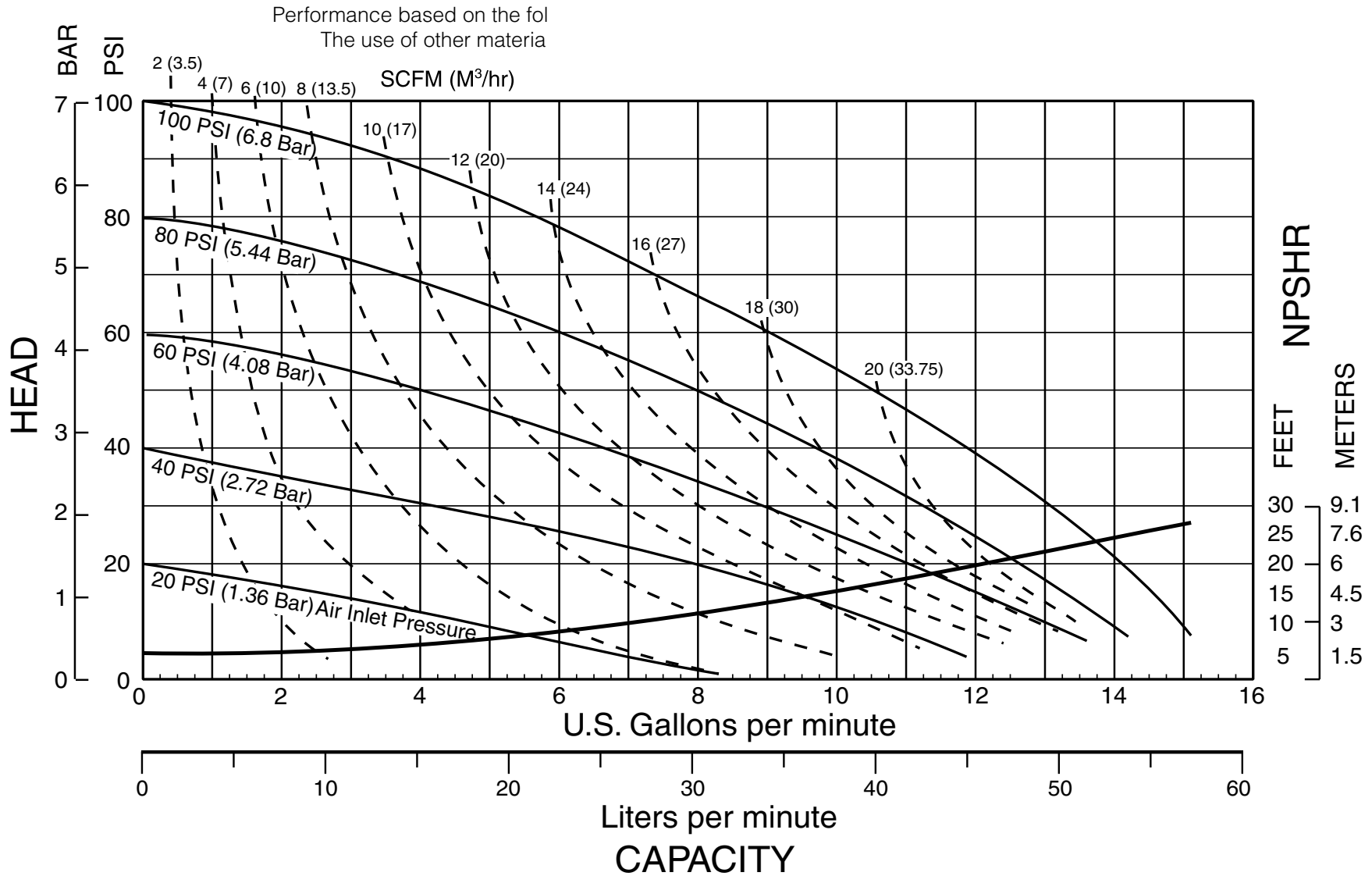

Dimensions:

Dimensions in Inches

Dimensional tolerance: $\pm 1/8$ "

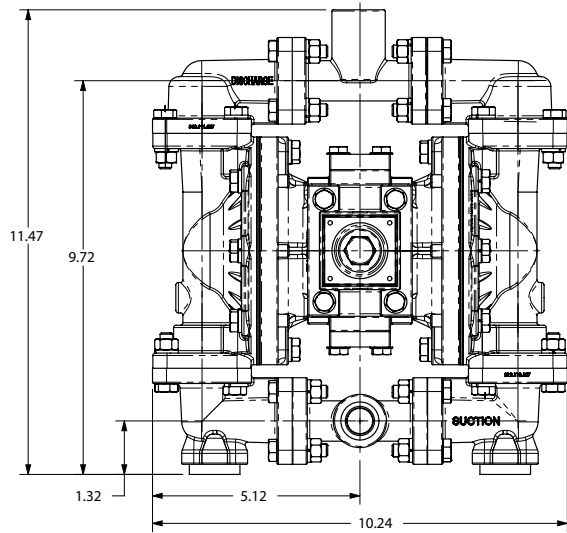

FRONT VIEW

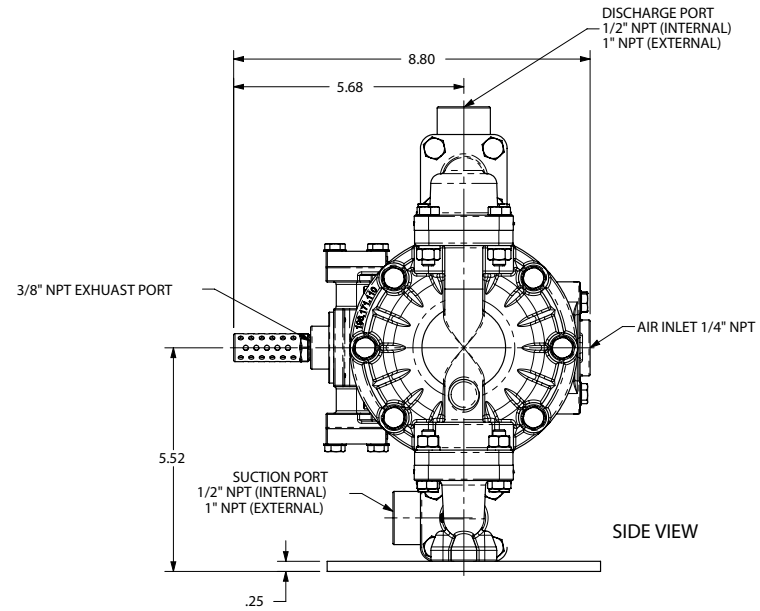

SIDE VIEW

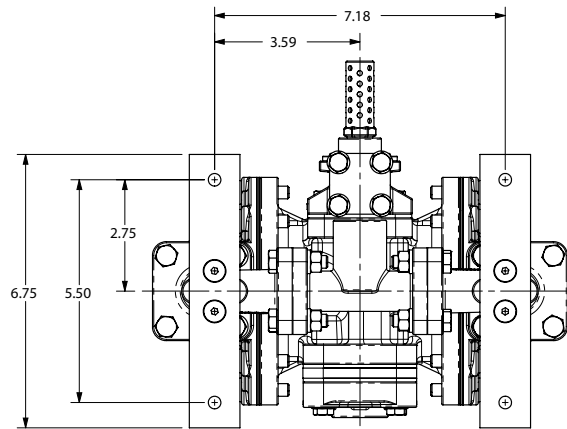

BOTTOM VIEW

METALLIC LINCOLN MODELS 85631, 85632, AND 85633

Dual Port Suction Dimensions:

Dimensions in inches

Dimensional tolerance: $\pm 1/8$ "

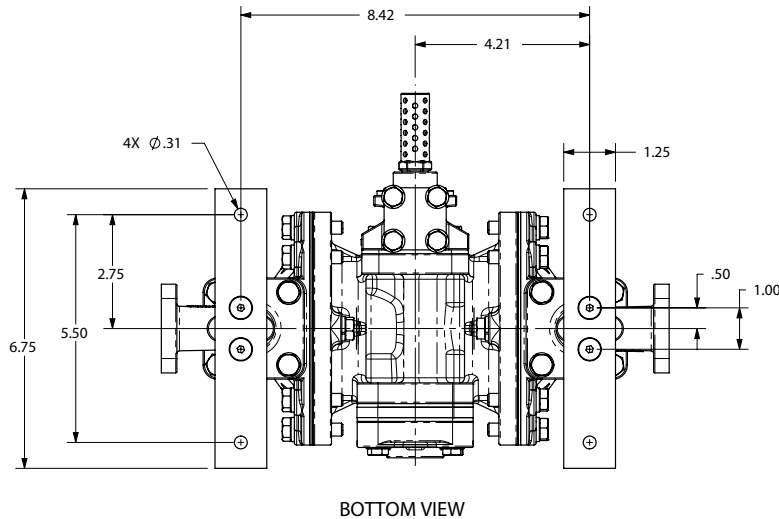
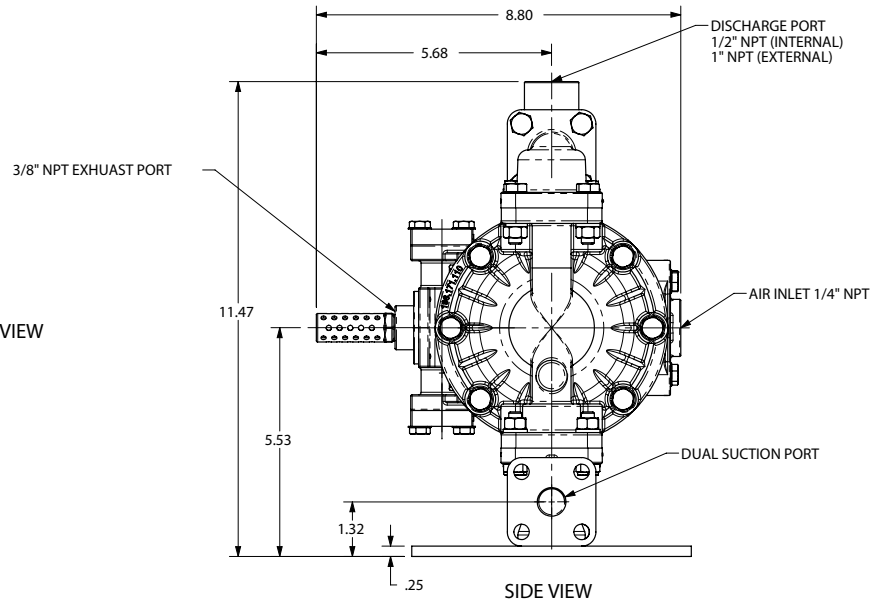
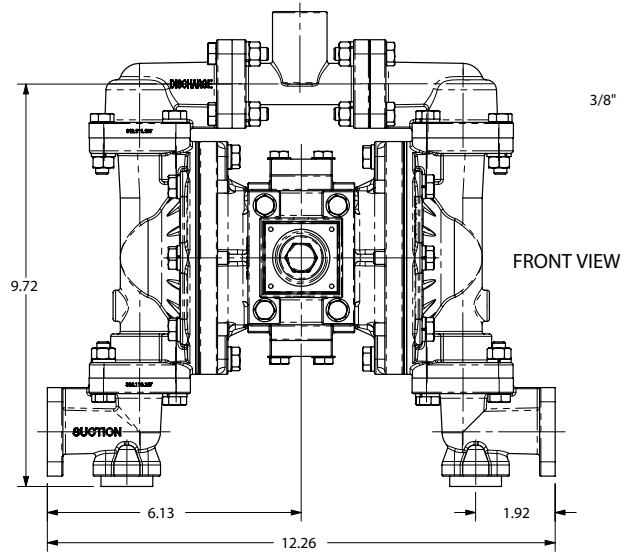

METALLIC LINCOLN MODEL 85636 DUAL SUCTION

PRINCIPLE OF PUMP OPERATION

This ball type check valve pump is powered by compressed air and is a 1:1 ratio design. The inner side of one diaphragm chamber is alternately pressurized while simultaneously exhausting the other inner chamber. This causes the diaphragms, which are connected by a common rod secured by plates to the centers of the diaphragms, to move in a reciprocating action. (As one diaphragm performs the discharge stroke the other diaphragm is pulled to perform the suction stroke in the opposite chamber.) Air pressure is applied over the entire inner surface of the diaphragm while liquid is discharged from the opposite side of the diaphragm. The diaphragm operates in a balanced condition during the discharge stroke which allows the pump to be operated at discharge heads over 200 feet (61 meters) of water.

For maximum diaphragm life, keep the pump as close to the liquid being pumped as possible. Positive suction head in excess of 10 feet of liquid (3.048 meters) may require a back pressure regulating device to maximize diaphragm life.

Alternate pressurizing and exhausting of the diaphragm chamber is performed by an externally mounted, pilot operated, four way spool type air distribution valve. When the spool shifts to one end of the valve body, inlet pressure is applied to one diaphragm chamber and the other diaphragm chamber exhausts. When the spool shifts to the opposite end of the valve body, the pressure to the chambers

is reversed. The air distribution valve spool is moved by an internal pilot valve which alternately pressurizes one end of the air distribution valve spool while exhausting the other end. The pilot valve is shifted at each end of the diaphragm stroke when an actuator plunger is contacted by the diaphragm plate. This actuator plunger then pushes the end of the pilot valve spool into position to activate the air distribution valve.

The chambers are connected with manifolds with a suction and discharge check valve for each chamber, maintaining flow in one direction through the pump.

INSTALLATION AND START-UP

Locate the pump as close to the product being pumped as possible. Keep the suction line length and number of fittings to a minimum. Do not reduce the suction line diameter.

For installations of rigid piping, short sections of flexible hose should be installed between the pump and the piping. The flexible hose reduces vibration and strain to the pumping system. A surge dampener is recommended to further reduce pulsation in flow.

AIR SUPPLY

Air supply pressure cannot exceed 100 psi (7 bar). Connect the pump air inlet to an air supply of sufficient capacity and pressure required for desired performance. When the air supply line is solid piping, use a short length of flexible hose not less than 1/2" (13mm) in diameter between the pump and the piping to reduce

strain to the piping. The weight of the air supply line, regulators and filters must be supported by some means other than the air inlet cap. Failure to provide support for the piping may result in damage to the pump. A pressure regulating valve should be installed to insure air supply pressure does not exceed recommended limits.

AIR VALVE LUBRICATION

The air distribution valve and the pilot valve are designed to operate WITHOUT lubrication. This is the preferred mode of operation. There may be instances of personal preference or poor quality air supplies when lubrication of the compressed air supply is required. The pump air system will operate with properly lubricated compressed air supply. Proper lubrication requires the use of an air line lubricator set to deliver one drop of SAE 10 non-detergent oil for every 20 SCFM (9.4 liters/sec.) of air the pump consumes at the point of operation. Consult the pump's published Performance Curve to determine this.

AIR LINE MOISTURE

Water in the compressed air supply can create problems such as icing or freezing of the exhaust air, causing the pump to cycle erratically or stop operating. Water in the air supply can be reduced by using a point-of-use air dryer to supplement the user's air drying equipment. This device removes water from the compressed air supply and alleviates the icing or freezing problems.

AIR INLET AND PRIMING

To start the pump, open the air valve approximately 1/2" to 3/4" turn. After the pump primes, the air valve can be opened to increase air flow as desired. If opening the valve increases cycling rate, but does not increase the rate of flow, cavitation has occurred. The valve should be closed slightly to obtain the most efficient air flow to pump flow ratio.

BETWEEN USES

When the pump is used for materials that tend to settle out or solidify when not in motion, the pump should be flushed after each use to prevent damage. (Product remaining in the pump between uses could dry out or settle out. This could cause problems with the diaphragms and check valves at restart.) In freezing temperatures the pump must be completely drained between uses in all cases.

INSTALLATION GUIDE

Top Discharge Ball Valve Unit

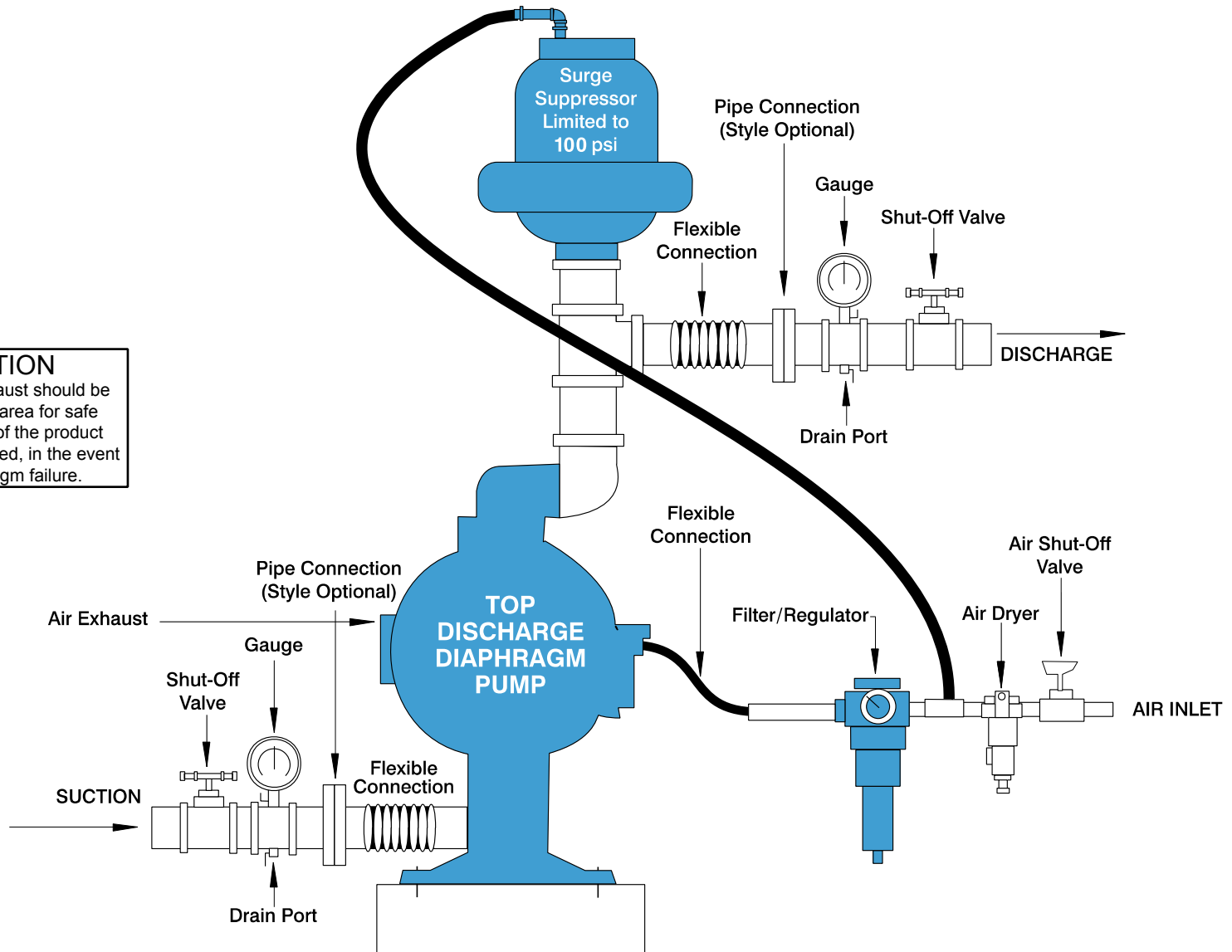
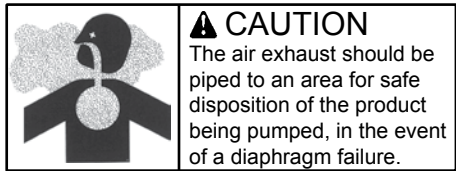

TROUBLESHOOTING

Possible Symptoms:

- Pump will not cycle.
- Pump cycles, but produces no flow.
- Pump cycles, but flow rate is unsatisfactory.
- Pump cycle seems unbalanced.
- Pump cycle seems to produce excessive vibration.

What to Check: Excessive suction lift in system.

Corrective Action: For lifts exceeding 20 feet (6 meters), filling the pumping chambers with liquid will prime the pump in most cases.

What to Check: Excessive flooded suction in system.

Corrective Action: For flooded conditions exceeding 10 feet (3 meters) of liquid, install a back pressure device.

What to Check: System head exceeds air supply pressure.

Corrective Action: Increase the inlet air pressure to the pump. Most diaphragm pumps are designed for 1:1 pressure ratio at zero flow.

What to Check: Air supply pressure or volume exceeds system head.

Corrective Action: Decrease inlet air pressure and volume to the pump as calculated on the published PERFORMANCE CURVE. Pump is cavitating the fluid by fast cycling.

What to Check: Undersized suction line.

Corrective Action: Meet or exceed pump connection recommendations shown on the DIMENSIONAL DRAWING.

What to Check: Restricted or undersized air line.

Corrective Action: Install a larger air line and connection. Refer to air inlet recommendations shown in your pump's SERVICE MANUAL.

What to Check: Check the externally serviceable air distribution system of the pump.

Corrective Action: Disassemble and inspect the main air distribution valve, pilot valve and pilot valve actuators. Refer to the parts drawing and air valve section of the SERVICE MANUAL. Check for clogged discharge or closed valve before reassembly.

What to Check: Rigid pipe connections to pump.

Corrective Action: Install flexible connectors and a Warren Rupp surge dampener.

What to Check: Blocked air exhaust muffler.

Corrective Action: Remove muffler screen, clean or de-ice and reinstall. Refer to the Air Exhaust section of your pump SERVICE MANUAL.

What to Check: Pumped fluid in air exhaust muffler.

Corrective Action: Disassemble pump chambers. Inspect for diaphragm rupture or loose diaphragm plate assembly. Refer to the Diaphragm Replacement section of your pump SERVICE MANUAL.

What to Check: Suction side air leakage or air in product.

Corrective Action: Visually inspect all suction side gaskets and pipe connections.

What to Check: Obstructed check valve.

Corrective Action: Disassemble the wet end of the pump and manually dislodge obstruction in the check valve pocket. Refer to the Check Valve section of the pump SERVICE MANUAL for disassembly instructions.

What to Check: Worn or misaligned check valve or check valve seat.

Corrective Action: Inspect check valves and seats for wear and proper seating. Replace if necessary. Refer to Check Valve section of the pump SERVICE MANUAL for disassembly instructions.

What to Check: Blocked suction line.

Corrective Action: Remove or flush obstruction. Check and clear all suction screens and strainers.

What to Check: Blocked discharge line.

Corrective Action: Check for obstruction or closed discharge line valves.

What to Check: Blocked pumping chamber.

Corrective Action: Disassemble and inspect the wetted chambers of the pump. Remove or flush any obstructions. Refer to the pump SERVICE MANUAL for disassembly instructions.

What to Check: Entrained air or vapor lock in one or both pumping chambers.

Corrective Action: Purge chambers through tapped chamber vent plugs. PURGING THE CHAMBERS OF AIR CAN BE DANGEROUS! A model with top-ported discharge will reduce or eliminate problems with entrained air.

If your pump continues to perform below your expectations, contact your technical services group for a service evaluation.

RECYCLING

Many components of LINCOLN Air-Operated Diaphragm pumps are made of recyclable materials (see chart on page 9 for material specifications). We encourage pump users to recycle worn out parts and pumps whenever possible, after any hazardous pumped fluids are thoroughly flushed.

⚠ WARNING

Systems which will be dispensing fluids under pressure may need to be protected by using a thermal relief kit which will safely limit the pressures caused by thermal expansion. Please contact your local Lincoln distributor and refer to Service Page Section K5 Page 31 for more details. Failure to include thermal relief protection may cause damage not covered under Lincoln's warranty policy.

IMPORTANT SAFETY INFORMATION

⚠ IMPORTANT



Read these safety warnings and instructions in this manual completely, before installation and start-up of the pump. It is the responsibility of the purchaser to retain this manual for reference. Failure to comply with the recommendations stated in this manual will damage the pump, and void factory warranty.

⚠ CAUTION



Before pump operation, inspect all gasketed fasteners for looseness caused by gasket creep. Retorque loose fasteners to prevent leakage. Follow recommended torques stated in this manual.

⚠ WARNING



Before maintenance or repair, shut off the compressed air line, bleed the pressure, and disconnect the air line from the pump. The discharge line may be pressurized and must be bled of its pressure.

⚠ WARNING



In the event of diaphragm rupture, pumped material may enter the air end of the pump, and be discharged into the atmosphere. If pumping a product which is hazardous or toxic, the air exhaust must be piped to an appropriate area for safe disposition.

⚠ WARNING



Take action to prevent static sparking. Fire or explosion can result, especially when handling flammable liquids. The pump, piping, valves, containers or other miscellaneous equipment must be grounded. (See page 32)

⚠ WARNING



This pump is pressurized internally with air pressure during operation. Always make certain that all bolting is in good condition and that all of the correct bolting is reinstalled during assembly.

⚠ WARNING



When used for toxic or aggressive fluids, the pump should always be flushed clean prior to disassembly.

⚠ WARNING



Before doing any maintenance on the pump, be certain all pressure is completely vented from the pump, suction, discharge, piping, and all other openings and connections. Be certain the air supply is locked out or made non-operational, so that it cannot be started while work is being done on the pump. Be certain that approved eye protection and protective clothing are worn all times in the vicinity of the pump. Failure to follow these recommendations may result in serious injury or death.

⚠ WARNING



Airborne particles and loud noise hazards. Wear ear and eye protection.



II 2GD T5

Pump complies with EN809 Pumping Directive, Directive 2006/42/EC Machinery, and Directive 94/9/EC, EN13463-1 Equipment for use in Potentially Explosive Environments. The Technical File No. AX1 is stored at KEMA, Notified Body 0344, under Document #203040000.

This page left intentionally blank

Composite Repair Parts Drawing, Models 85631, 85632, 85633

Available Service and Conversion Kits

Part No.	Description
273031	AIR END KIT Seals, O-rings, Gaskets, Retaining Rings, Air Valve Assembly and Pilot Valve Assembly.
271856	WETTED END KIT Hytrel Diaphragm, Hytrel Check Balls, UHMW Seats, Buna Spacer Gasket. (For Model 85633)
271854	WETTED END KIT Buna Diaphragm, Buna Check Balls, UHMW Seats. (For Models 85631 & 85636)
271855	WETTED END KIT Santoprene Diaphragm, PTFE Overlay Diaphragm, PTFE Check Balls, PTFE Seats. (For Model 85632)

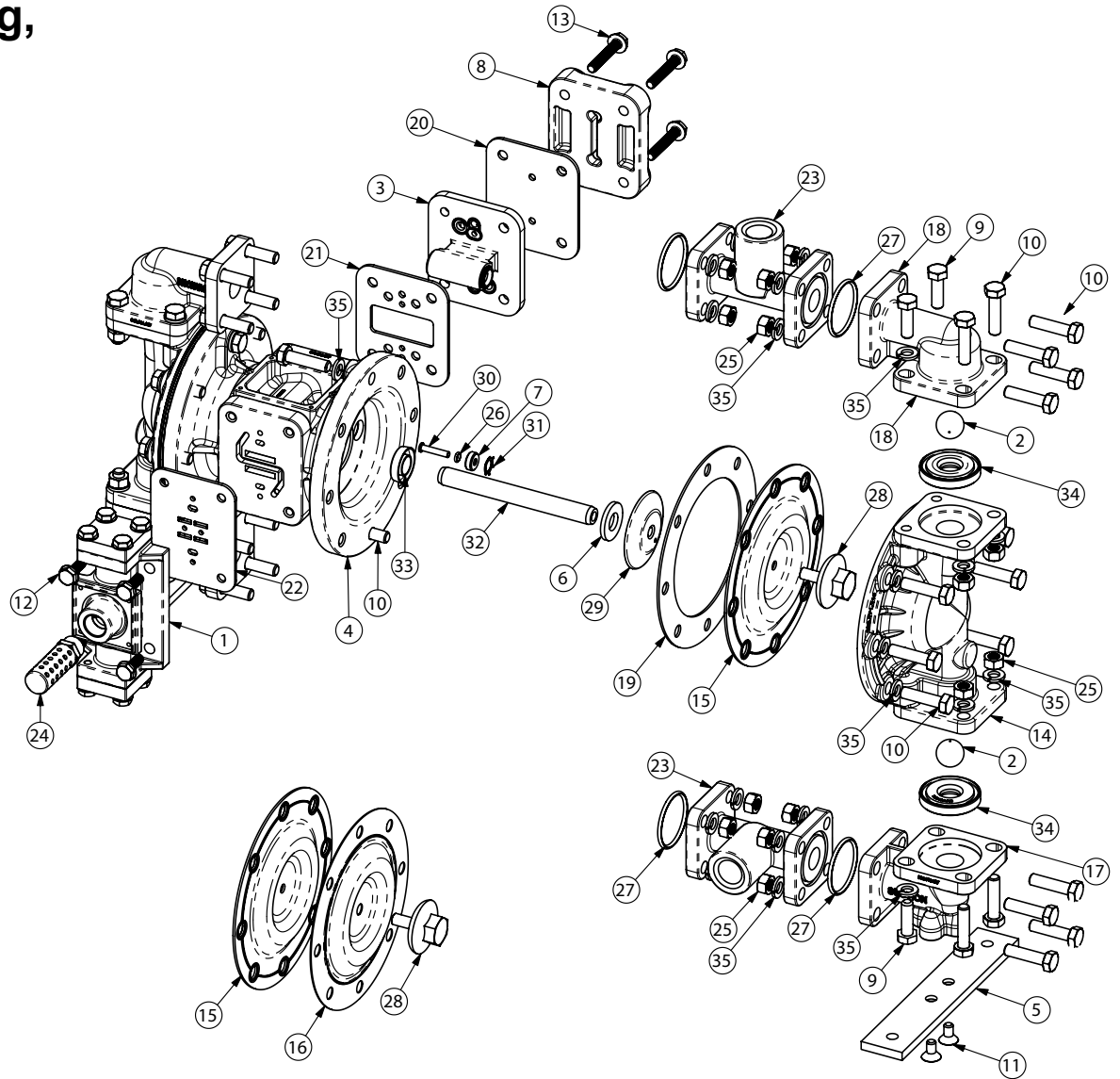

Composite Repair Parts List, Models 85631, 85632, 85633

Item	Description	Qty	Model 85631	Model 85632	Model 85633
1	Air Valve Assembly	1	275808	275808	275808
2	Check Ball	4	272208	252896	272209
3	Pilot Valve Assembly	1	275749	275749	275749
4	Intermediate Bracket	1	273026	273026	273026
5	Mounting Foot	2	271857	271857	271857
6	Bumper	2	252900	252900	252900
7	Plunger Bushing	2	252901	252901	252901
8	Air Inlet Cap	1	275747	275747	275747
9	Hex Capscrew 5/16-18UNC 2A x 1.00	8	275754	275754	275754
10	Hex Capscrew 5/16-18UNC 2A x 1.25	40	240731	240731	240731
11	Hex Socket Flat Head Screw 1/4-20UNC 2A	4	271858	271858	271858
12	Hex Flanged Capscrew 1/4-20 x .75	4	275755	275755	275755
13	Hex Flanged Capscrew 1/4-20 x 1.50	4	275756	275756	275756
14	Outer Chamber	2	271864	271864	271864
15	Diaphragm	2	271865	252907	272213
16	Overlay Diaphragm	2		252908	
17	Suction Elbow 1/2" NPT Threaded Suction Elbow	2	271866	271866	271866
18	Discharge Elbow	2	271867	271867	271867
19	Not used				
20	Air Inlet Gasket	1	273028	273028	273028
21	Pilot Valve Gasket	1	275573	275573	275573
22	Air Valve Gasket	1	252913	252913	252913
23	Manifold	2	271868	271868	271868
24	Metal Muffler	1	273032	273032	273032
25	Hex Nut 5/16-18UNC 2B	24	240722	240722	240722
26	O-ring	2	240655	240655	240655
27	Manifold O-ring Manifold Seal	4 4	244191	272214	272214
28	Outer Diaphragm Plate	2	240673	240673	240673
29	Inner Diaphragm Plate	2	275753	275753	275753
30	Actuator Plunger	2	252918	252918	252918
31	Retaining Ring	2	240717	240717	240717
32	Diaphragm Rod	1	252920	252920	252920
33	U-Cup Seal	2	252921	252921	252921
34	Check Valve Seat	4	276247	271870	276247
35	Lock Washer 5/16	48	240693	240693	240693



Note: Atex Compliant

Composite Repair Parts Drawing, Dual Port Suction Model 85636

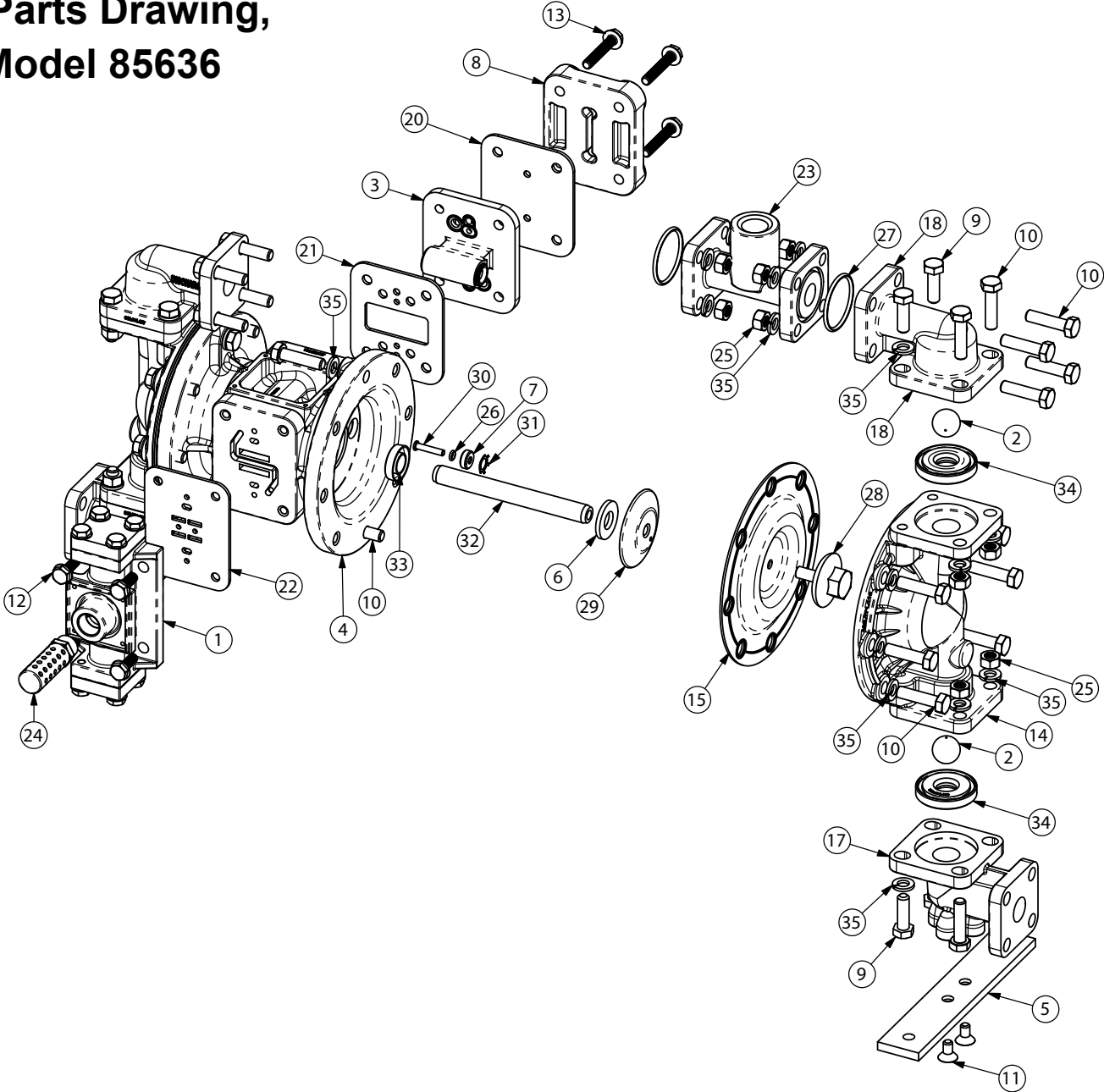

Composite Repair Parts List, Dual Port Suction Model 85636

Item	Description	Qty	Model 85636
1	Air Valve Assembly	1	275808
2	Check Ball	4	272208
3	Pilot Valve Assembly	1	275749
4	Intermediate Bracket	1	273026
5	Mounting Foot	2	271857
6	Bumper	2	252900
7	Plunger Bushing	2	252901
8	Air Inlet Cap	1	275747
9	Hex Capscrew 5/16-18UNC 2A x 1.00	8	275754
10	Hex Capscrew 5/16-18UNC 2A x 1.25	32	240731
11	Hex Socket Flat Head Screw 1/4-20UNC 2A	4	271858
12	Hex Flanged Capscrew 1/4-20 x .75	4	275755
13	Hex Flanged Capscrew 1/4-20 x 1.50	4	275756
14	Outer Chamber	2	271864
15	Diaphragm	2	271865
17	Suction Elbow 1/2" NPT Threaded Suction Elbow	2	275563
18	Discharge Elbow	2	271867
20	Air Inlet Gasket	1	273028
21	Pilot Valve Gasket	1	275573
22	Air Valve Gasket	1	252913
23	Manifold	1	271868
24	Metal Muffler	1	273032
25	Hex Nut 5/16-18UNC 2B	16	240722
26	O-ring	2	240655
27	Manifold O-ring Manifold Seal	2	244191
28	Outer Diaphragm Plate	2	240673
29	Inner Diaphragm Plate	2	275753
30	Actuator Plunger	2	252918
31	Retaining Ring	2	240717
32	Diaphragm Rod	1	252920
33	U-Cup Seal	2	252921
34	Check Valve Seat	4	276247
35	Lock Washer 5/16	40	240693



Note: Atex Compliant

Distribution Valve Assembly Drawing

Reference Part Number from Pages 10 and 11; also pages 12 and 13.

MAIN AIR VALVE ASSEMBLY PARTS LIST

Item	Part Number	Description	Qty
1-A	252929	Sleeve and Spool Set with O-rings	1
1-B	275745	Valve Body	1
1-C	275746	Bumper	2
1-D	275748	End Cap	2
1-E	275755	Hex Flange Capscrew 1/4-20UNC 2A x .75	8
1-F	252927	O-ring	4

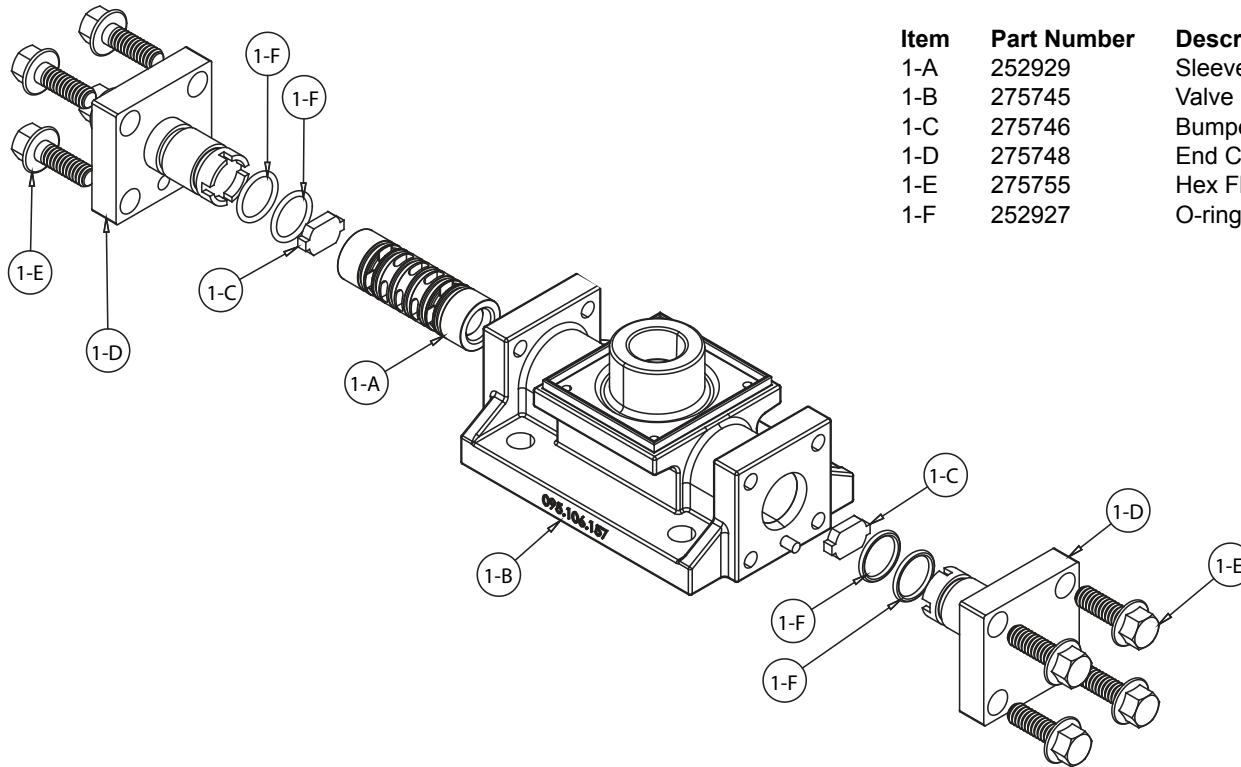

AIR DISTRIBUTION VALVE SERVICING

To service the air valve first shut off the compressed air, bleed pressure from the pump, and disconnect the air supply line from the pump.

Step #1: See COMPOSITE REPAIR PARTS DRAWING.

Using a 3/8" wrench or socket, remove the four hex capscrews (items 12). Remove the air valve assembly from the pump.

Remove and inspect gasket (item 21) for cracks or damage. Replace gasket if needed.

Step #2: Disassembly of the air valve.

Using a 3/8" wrench or socket, remove the eight hex capscrews (items 1-E) that fasten the end caps to the valve body. Next remove the two end caps (items 1-D). Inspect the two o-rings (items 1-F) on each end cap for damage or wear. Replace the o-rings as needed.

Remove the bumpers (items 1-C). Inspect the bumpers for damage or wear. Replace the bumpers as needed.

Remove the spool (part of item 1-A) from the sleeve. Be careful not to scratch or damage the outer diameter of the spool. Wipe spool with a soft cloth and inspect for scratches or wear.

Inspect the inner diameter of the sleeve (part of item 1-A) for dirt,

scratches, or other contaminants. Remove the sleeve if needed and replace with a new sleeve and spool set (item 1-A).

Step #3: Reassembly of the air valve.

Install one bumper (item 1-C) and one end cap (item 1-D), with two o-rings (items 1-F), and fasten with four hex capscrews (items 1-E) to the valve body (item 1-B). Align hole in end cap with roll pin on valve body.

Remove the new sleeve and spool set (item 1-A) from the plastic bag. Carefully remove the spool from the sleeve. Install the six o-rings (item 1-F) into the six grooves on the sleeve. Apply a light coating of grease to the o-rings before installing the sleeve into the valve body (item 1-B), align the slots in the sleeve with the slots in the valve body. Insert the spool into the sleeve. Be careful not to scratch or damage the spool during installation. Install the remaining bumper and end cap (with o-rings), and fasten with the remaining hex capscrews. Align hole in end cap with roll pin on valve body.

Fasten the air valve assembly (item 1) and gasket to the pump. Connect the compressed air line to the pump. The pump is now ready for operation.

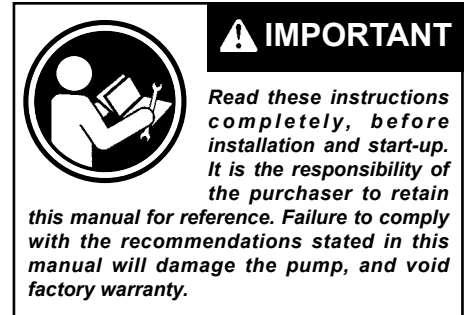

Diaphragm Service Drawing

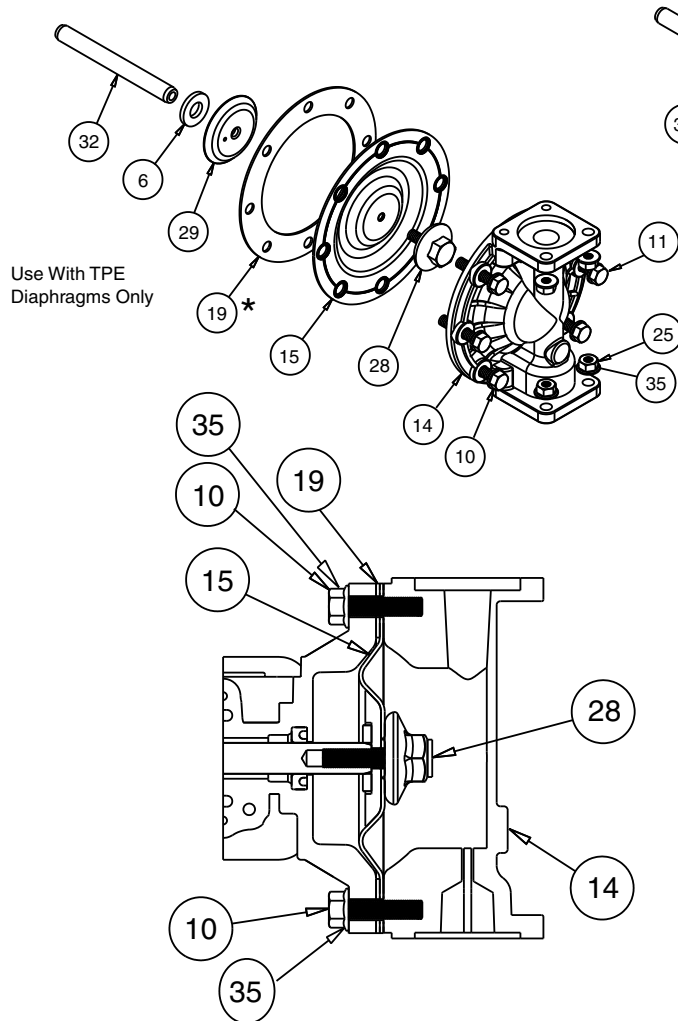

Diaphragm Orientation

Install diaphragm and spacer as shown above.

Diaphragm Service Drawing, with Overlay

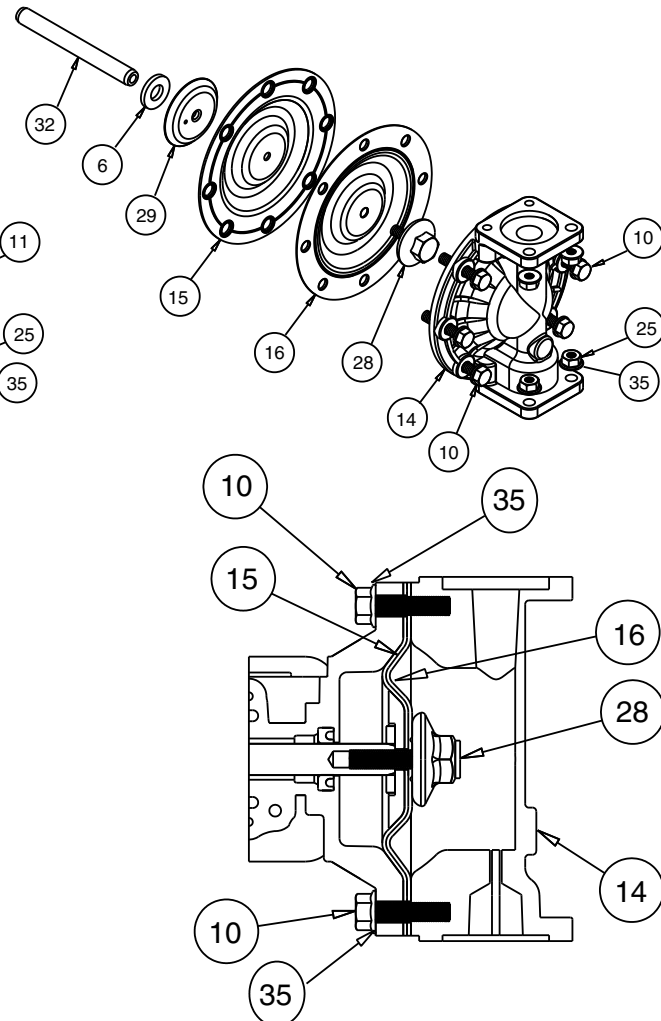

Diaphragm Orientation

Install diaphragm and overlay as shown above.

DIAPHRAGM SERVICING

To service the diaphragm first shut off the suction, then shut off the discharge lines to the pump. Shut off the compressed air supply, bleed the pressure from the pump, and disconnect the air supply line from the pump. Drain any remaining liquid from the pump.

Step #1: See the pump composite repair parts drawing, and the diaphragm servicing illustration.

Using a 1/2" wrench or socket, remove 8 capscrews (items 9 & 10), washers and nuts that fasten the discharge elbows (item 18) or the discharge manifold (item 23). Remove the elbows and manifold assembly (items 18 & 23). Use the same procedure to remove the suction elbows (item 17) or suction manifold (item 24).

Step #2: Removing the outer chambers. Using a 1/2" wrench or socket, remove the 16 capscrews (item 10), washers that fasten the outer chambers (item 14), diaphragms (items 15 & 16) and intermediate bracket (item 4) together.

Step #3: Removing the diaphragm assemblies.

Use a 3/4" (19mm) wrench or six pointed socket to remove the diaphragm assemblies (outer plate, diaphragm, and inner plate) from the diaphragm rod (item 32) by turning counterclockwise.

Insert a 6-32 set screw into the smaller tapped hole in the inner diaphragm plate (item 29). Insert the protruding stud and the 6-32 fastener loosely into a vise. Use a 3/4" wrench or socket to remove the outer diaphragm plate (item 28) by turning counterclockwise. Inspect the diaphragm (item 15 & 16) for cuts, punctures, abrasive wear or chemical attack. Replace the diaphragms if necessary.

Step #4: Installing the diaphragms. Push the threaded stud of the outer diaphragm plate through the center hole of the diaphragm. Thread the inner plate clockwise onto the stud. Insert the loose assembly with the above 6-32 fastener back into the vise. Use a torque wrench to tighten the diaphragm assembly together to 7.5 ft. Lbs. (10.17 Newton meters). Allow a minimum of 15 minutes to elapse after torquing, then re-torque the assembly to compensate for stress relaxation in the clamped assembly.

Step #5: Installing the diaphragm assemblies to the pump.

Make sure the bumper (item 6) is installed over the diaphragm rod.

Thread the stud of the one diaphragm assembly clockwise into the tapped hole at the end of the diaphragm rod (item 34) until the inner diaphragm plate is flush to the end of the rod. Insert rod into pump.

Align the bolt holes in the diaphragm with the bolt pattern in the intermediate (item 4).

Fasten the outer chamber (item 14) to the pump, using the capscrews (item 10) washers.

On the opposite side of the pump, pull the diaphragm rod out as far as possible. Make sure the bumper (item 6) is installed over the diaphragm rod.

Thread the stud of the remaining diaphragm assembly clockwise into the tapped hole at the end of the diaphragm rod (item 32) as far as possible and still allow for alignment of the bolt holes in the diaphragm with the bolt pattern in the inner chamber. Install diaphragms with convolutions facing towards center of pump. See sectional view on previous page.

Fasten the remaining outer chamber (item 14) to the pump, using the capscrews (item 10) and washers.

Step #6: Re-install the elbow/manifold assemblies to the pump, using the capscrews (items 9 and 10) washers and nuts.

The pump is now ready to be re-installed, connected and returned to operation.

OVERLAY DIAPHRAGM SERVICING

The overlay diaphragm (item 16) is designed to fit snugly over the exterior of the standard TPE diaphragm (item 15).



! IMPORTANT

Read these instructions completely, before installation and start-up. It is the responsibility of the purchaser to retain this manual for reference. Failure to comply with the recommendations stated in this manual will damage the pump, and void factory warranty.

Pilot Valve Servicing, Assembly Drawing & Parts List

PILOT VALVE ASSEMBLY PARTS LIST

Reference Part Number from Pages 10 and 11; also pages 12 and 13.

ITEM	PART NUMBER	DESCRIPTION	QTY
3-A	275750	Pilot Valve Body	1
3-B	274585	Pilot Valve Sleeve with O-rings	1
3-C	275751	O-ring	6
3-D	274587	Pilot Valve Spool with O-rings	1
3-E	275752	O-ring	3
3-F	274589	Retaining Ring	1

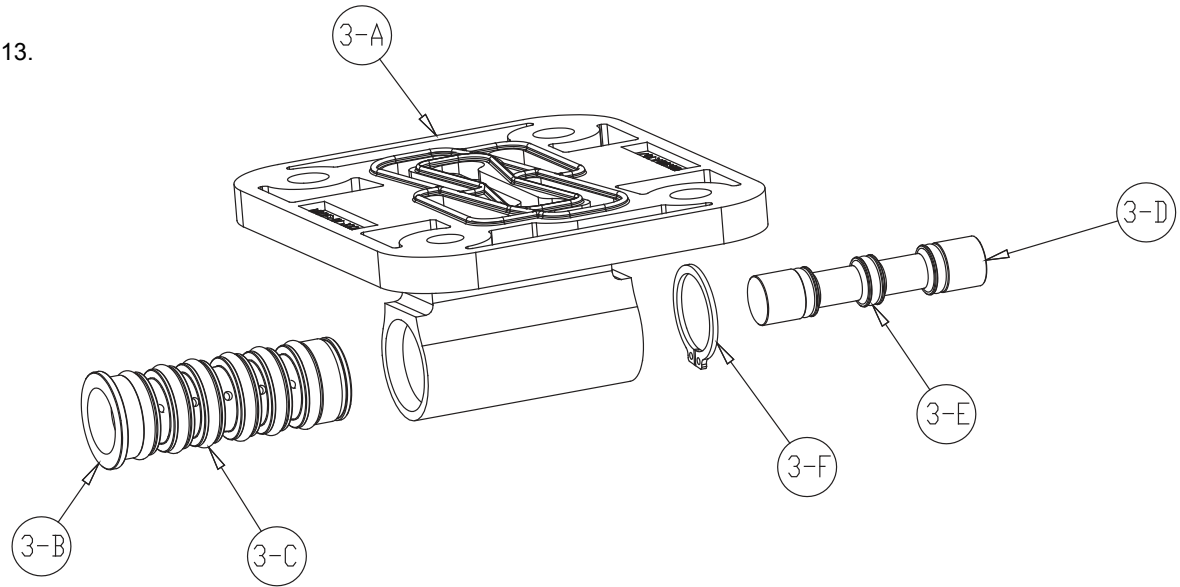

PILOT VALVE SERVICING

To service the pilot valve first shut off the compressed air supply, bleed the pressure from the pump, and disconnect the air supply line from the pump.

STEP #1: See pump assembly drawing.

Using a 7/16" wrench or socket, remove the four capscrews (item 13). Remove the air inlet cap (item 8) and air inlet gasket (item 20). The pilot valve assembly (item 3) can now be removed for inspection and service.

STEP #2: Disassembly of the pilot valve.

Remove the pilot valve spool (item 3-D). Wipe clean and inspect spool and o-rings for dirt, cuts or wear. Replace the o-rings and spool if necessary.

Remove the retaining ring (item 3-F) from the end of the sleeve (item 3-B) and remove the sleeve from the valve body (item 3-A). Wipe clean and inspect sleeve and o-rings for dirt, cuts or wear. Replace the o-rings and sleeve if necessary.

STEP #3: Re-assembly of the pilot valve.

Generously lubricate outside diameter of the sleeve and o-rings. Then carefully insert sleeve into valve body. Take CAUTION when inserting sleeve, not to shear any o-rings. Install retaining ring to sleeve. Generously lubricate outside diameter of spool and o-rings. Then carefully insert spool into sleeve. Take CAUTION when inserting spool, not to shear any o-rings. Use BP-LS-EP-2 multipurpose grease, or equivalent.

STEP #4: Re-install the pilot valve assembly into the intermediate.

Be careful to align the ends of the pilot valve stem between the plunger pins when inserting the pilot valve into the cavity of the intermediate.

Re-install the gasket, air inlet cap and capscrews. Connect the air supply to the pump. The pump is now ready for operation.

Intermediate Assembly Drawing

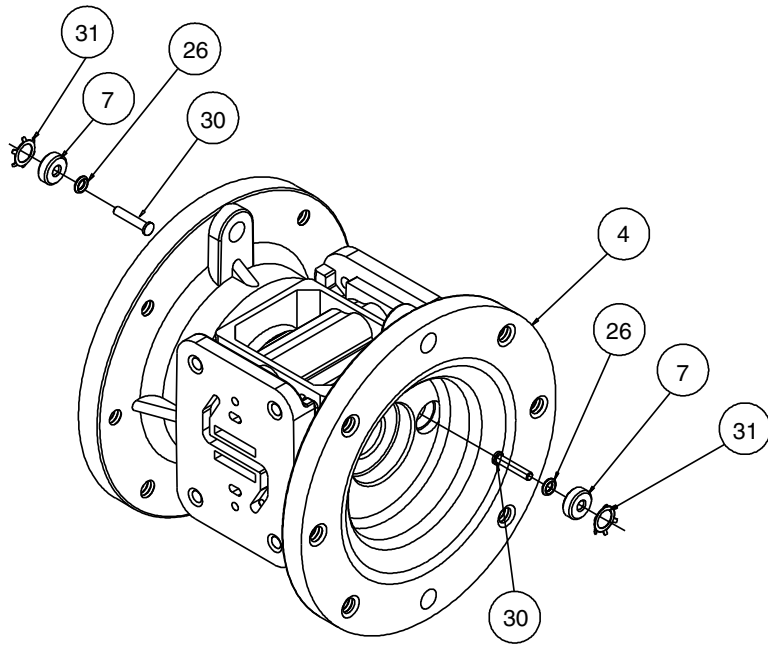

INTERMEDIATE REPAIR PARTS LIST

ITEM	PART NUMBER	DESCRIPTION	QTY
4	273026	Bracket, Intermediate	1
7	252901	Bushing, Plunger	2
26	240655	O-Ring	2
30	252918	Plunger, Actuator	2
31	240717	Ring, Retaining*	2

***NOTE:** It is recommended that when plunger components are serviced, new retaining rings be installed.

Intermediate Assembly Servicing

ACTUATOR PLUNGER SERVICING

To service the actuator plunger first shut off the compressed air supply, bleed the pressure from the pump, and disconnect the air supply line from the pump.

Step #1: See PUMP ASSEMBLY DRAWING.

Using a 3/8" wrench or socket, remove the four capscrews (items 13). Remove the air inlet cap (item 8) and air inlet gasket (item 20). The pilot valve assembly (item 3) can now be removed.

Step #2: Servicing the actuator plungers.

See PUMP ASSEMBLY DRAWING. The actuator plungers (items 30) can be reached through the stem cavity of the pilot valve in the intermediate bracket (item 4). To service bushings, o-rings and retaining rings, see Intermediate Drawing.

Remove the plungers (items 30) from the bushings (item 7) in each end of the intermediate cavity. Inspect for wear or damage. Replace plunger as needed. Apply a light coating of grease to each o-ring and re-install the plungers in to the bushings. Push the plungers in as far as they will go.

Step #3: Re-install the pilot valve

assembly into the intermediate assembly.

Be careful to align the ends of the stem between the plungers when inserting the stem of the pilot valve into the cavity of the intermediate.

Re-install the gasket (item 20), air inlet cap (item 8) and capscrews (items 13).

Connect the air supply to the pump. The pump is now ready for operation.

PLUNGER BUSHING, O-RING, AND RETAINING RING SERVICING

To service the plunger bushing components first remove the two retaining rings (items 31) using a small flat screwdriver. ***Note:** It is recommended that new retaining rings be installed.

Next remove the two plunger bushings (items 7). Inspect the bushings for wear or scratches. Replace the bushings as necessary.

Inspect the two o-rings (26) for cuts and/or wear.

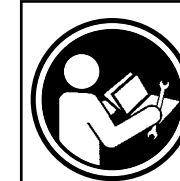

! IMPORTANT

Read these instructions completely, before installation and start-up. It is the responsibility of the purchaser to retain this manual for reference. Failure to comply with the recommendations stated in this manual will damage the pump, and void factory warranty.

CHECK VALVE SERVICING

Before servicing the check valve components, first shut off the suction line and then the discharge line to the pump. Next, shut off the compressed air supply, bleed air pressure from the pump, and disconnect the air supply line from the pump. Drain any remaining fluid from the pump. The pump can now be removed for service.

To access the check valve components, remove the manifold/manifold assembly. Use a 1/2" wrench or socket to remove the fasteners. Once the manifold is removed, the check valve components can be seen.

Inspect the check balls (items 2) for wear, abrasion, or cuts on the spherical surface. The check valve seats (item 34) should be inspected for cuts, abrasive wear, or embedded material on the surfaces of both the external and internal chambers. The spherical surface of the check balls must seat flush to the surface of the check valve seats for the pump to operate to peak efficiency. Replace any worn or damaged parts as necessary.

Re-assemble the check valve components. The seat should fit into the counter bore of the outer chamber.

The pump can now be reassembled, reconnected and returned to operation.

Check Valve Drawing

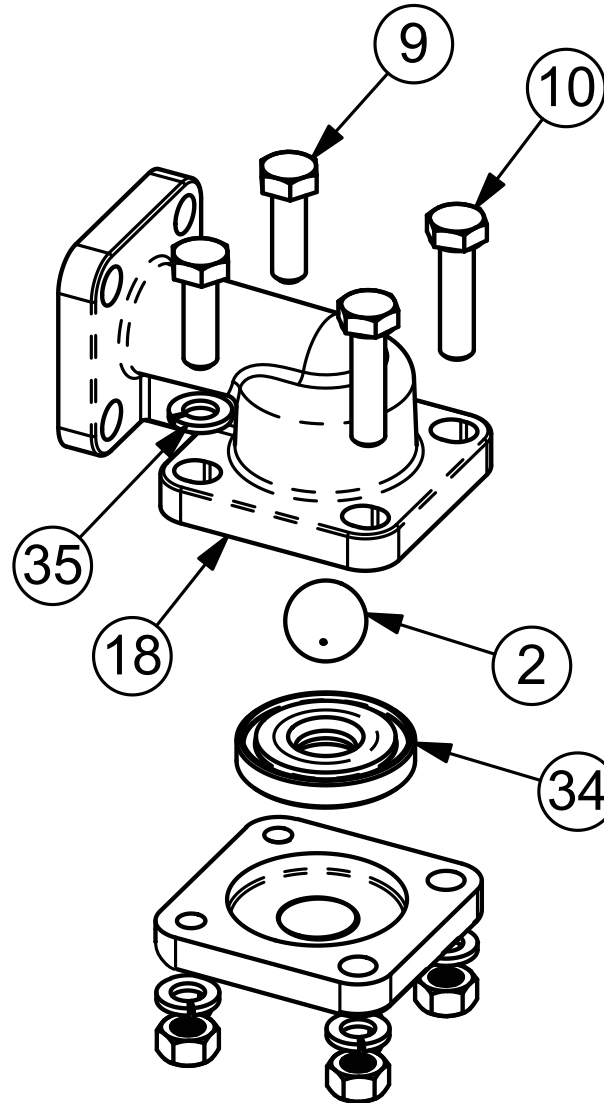

PUMPING HAZARDOUS LIQUIDS

When a diaphragm fails, the pumped liquid or fumes enter the air end of the pump. Fumes are exhausted into the surrounding environment. When pumping hazardous or toxic materials, the exhaust air must be piped to an appropriate area for safe disposal. See illustration #1 at right.

This pump can be submerged if the pump materials of construction are compatible with the liquid being pumped. The air exhaust must be piped above the liquid level. See illustration #2 at right. Piping used for the air exhaust must not be smaller than 1/2" (1.27 cm) diameter. Reducing the pipe size will restrict air flow and reduce pump performance. When the pumped product source is at a higher level than the pump (flooded suction condition), pipe the exhaust higher than the product source to prevent siphoning spills. See illustration #3 at right.

CONVERTING THE PUMP FOR PIPING THE EXHAUST AIR

The following steps are necessary to convert the pump to pipe the exhaust air away from the pump.

Use a Phillips screwdriver to remove the four self-tapping screws (item 1-H).

Remove the muffler cap and muffler (items 1-G and 1-F). The 3/8" NPT molded threads in the air distribution valve body (item 1-A).

Piping or hose may now be installed.

IMPORTANT INSTALLATION NOTE:

The manufacturer recommends installing a conductive flexible hose or connection between the pump and any rigid plumbing. This reduces stresses on the molded plastic threads of the air exhaust port. Failure to do so may result in damage to the air distribution valve body.

Any piping or hose connected to the pump's air exhaust port must be conductive and physically supported. Failure to support these connections could also result in damage to the air distribution valve body.

Exhaust Conversion Drawing

Air Valve Assembly

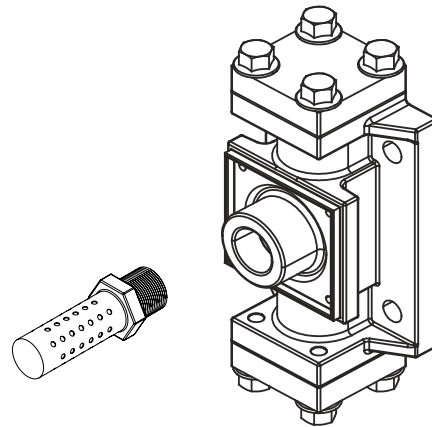

On ATEX compliant units the pump comes equipped with a metal muffler

CONVERTED EXHAUST ILLUSTRATION

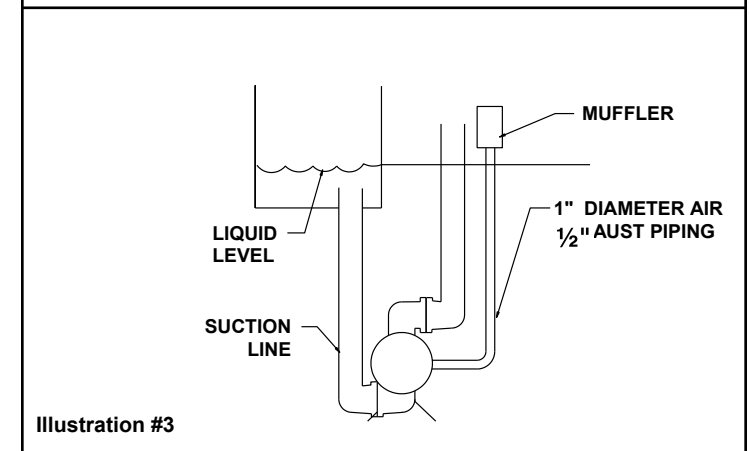
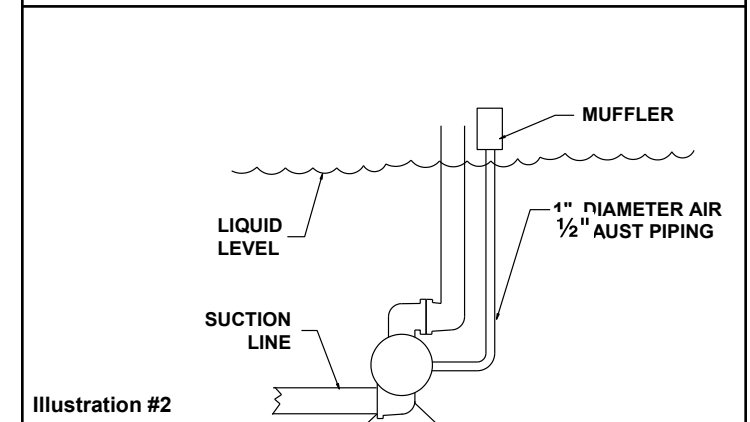
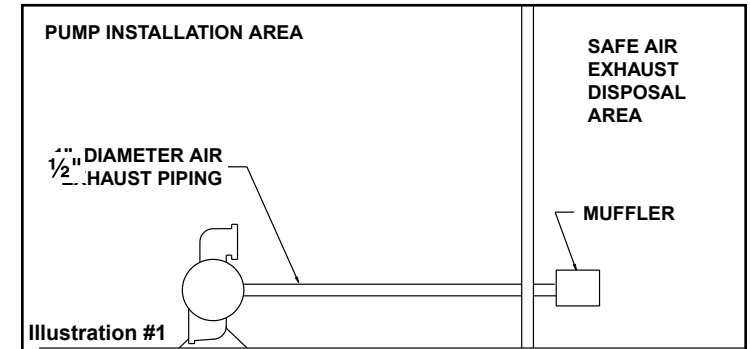

Grounding The Pump

To be fully groundable, the pumps must be ATEX Compliant.

One eyelet is fastened to the pump hardware.

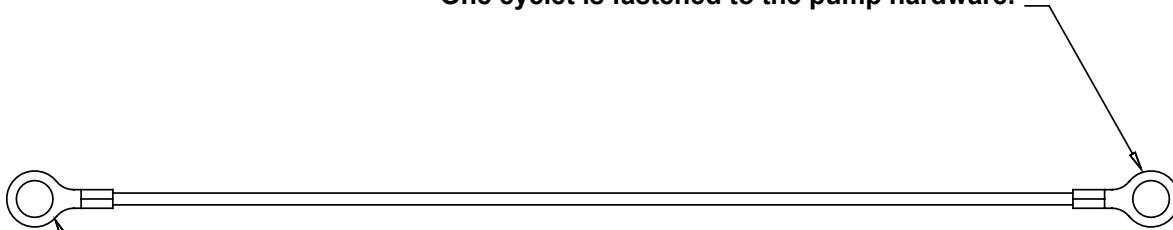

One eyelet is installed to a true earth ground.
(Requires a 5/16 or 8mm maximum diameter bolt)

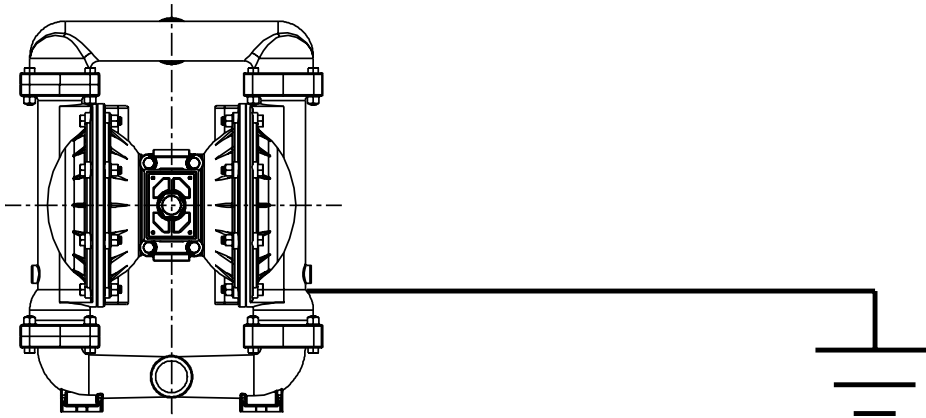

To reduce the risk of static electrical sparking, this pump must be grounded. Check the local electrical code for detailed grounding instruction and the type of equipment required.

	! WARNING
	<i>Take action to prevent static sparking. Fire or explosion can result, especially when handling flammable liquids. The pump, piping, valves, containers or other miscellaneous equipment must be grounded.</i>

Declaration of Conformity



Declaration of Conformity

LINCOLN®, One Lincoln Way, St. Louis, MO 63120-1578,
certifies that Air-Operated Double Diaphragm Pumps Series:
B comply with the European Community Directive 2006/42/EC
Machinery. This product has used EN 809, Pumps and Pump
Units for Liquids - Common Safety Requirements harmonized standard
to verify conformance.

Anna Wash

Signature of authorized person

February 19, 2008

Date of issue

Ayzik Grach

Printed name of authorized person

MANAGER, PRODUCT ENG.

Title

CE

Declaration of Conformity