

PowerLuber grease gun (lithium ion)

1880, 1882 and 1884 series “A”

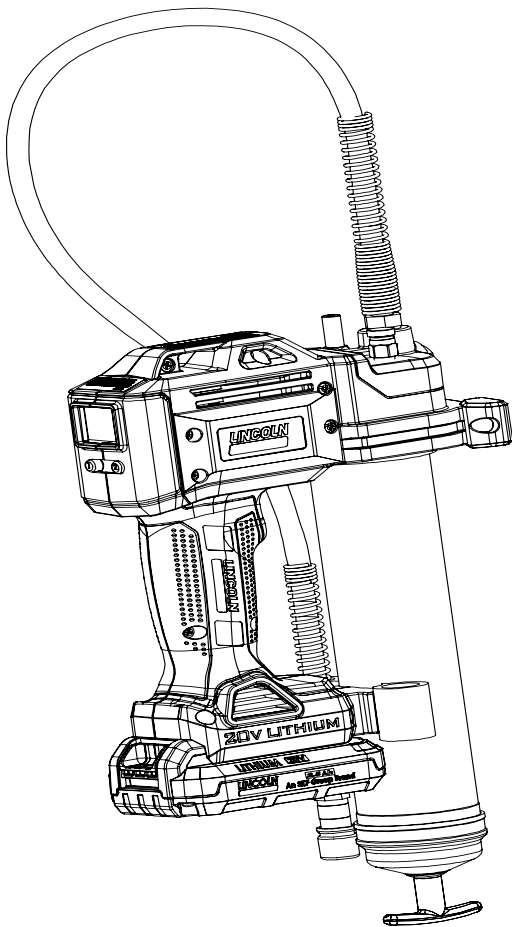

Date of issue	June 2020
Form number	423077
Version	3

Contents

Intended use	3
Safety instruction	3
Safety of others	4
Specific Safety	4
Residual risks	5
Vibration	5
Labels of tools	5
Maintenance	5
Safety instructions for battery and charger	6
Batteries	6
Charger	7
Electrical	7
Tool use and care	8
Specifications	8
Models	9
General description	9
Control center	9
Inspection	10
Operation	10
LCD display and LED light	10
Grease flow monitoring	11
Replace grease cartridge or refill tube	11
Priming instructions	11
Install grease cartridge	11
To fill gun from bulk container	12
To fill gun with filler pump	12
To expel air pockets (air purging)	12
Charger operation	12
Charger procedure	13
Important charging notices	13
Exploded drawings	14
Service parts list	16
Troubleshooting	17
Declaration of conformity	18
Warranty	20

Explanation of signal words for safety

NOTE

Emphasizes useful hints and recommendations as well as information for efficient and trouble-free operation.

⚠ CAUTION

Indicates a dangerous situation that can lead to light personal injury or property damage if precautionary measures are ignored.

⚠ WARNING

Indicates a dangerous situation that could lead to death or serious injury if precautionary measures are ignored.

⚠ DANGER

Indicates a dangerous situation that will lead to death or serious injury if precautionary measures are ignored.

Intended use

The PowerLuber was exclusively designed to pump and dispense lubricant using 20 V battery pack. Do not exceed maximum specification ratings.

Safety instruction

General power tool safety warnings

⚠ WARNING

 **Read all safety warnings and instructions.** Failure to follow the warnings and instructions may result in electric shock, fire and/or serious injury.

Save all warnings and instructions for future reference. The term “power tool” in the warnings refers to your mains-operated (corded) power tool or battery-operated (cordless) power tool.

1 Work area safety

1.1 Keep work area clean and well lit.

Cluttered or dark areas invite accidents.

1.2 Do not operate power tools in explosive atmospheres, such as in the presence of flammable liquids, gases or dust.

Power tools create sparks which may ignite the dust or fumes.

1.3 Keep children and bystanders away while operating a power tool.

Distractions can cause you to lose control.

2 Electrical safety

2.1 Power tool plugs must match the outlet. Never modify the plug in any way. Do not use any adapter plugs with earthed (grounded) power tools.

Unmodified plugs and matching outlets will reduce risk of electric shock.

2.2 Avoid body contact with earthed or grounded surfaces such as pipes, radiators, ranges and refrigerators.

There is an increased risk of electric shock if your body is earthed or grounded.

2.3 Do not expose power tools to rain or wet conditions.

Water entering a power tool will increase the risk of electric shock.

2.4 Do not abuse the cord. Never use the cord for carrying, pulling or unplugging the power tool. Keep cord away from heat, oil, sharp edges or moving parts.

Damaged or entangled cords increase the risk of electric shock.

2.5 When operating a power tool outdoors, use an extension cord suitable for outdoor use.

Use of a cord suitable for outdoor use reduces the risk of electric shock.

2.6 If operating a power tool in a damp location is unavoidable, use a Residual Current Device (RCD) protected supply.

Use of an RCD reduces the risk of electric shock.

3 Personal safety

3.1 Stay alert, watch what you are doing and use common sense when operating a power tool.

Do not use a power tool while you are tired or under the influence of drugs, alcohol or medication. A moment of inattention while operating power tools may result in serious personal injury.

3.2 Use personal protective equipment. Always wear eye protection.

Protective equipment such as dust mask, non-skid safety shoes, hard hat, or hearing protection used for appropriate conditions will reduce personal injuries.

3.3 Prevent unintentional starting. Ensure the switch is in the off-position before connecting to power source and/or battery pack, picking up or carrying the tool.

Carrying power tools with your finger on the switch or energising power tools that have the switch on invites accidents.

3.4 Remove any adjusting key or wrench before turning the power tool on.

A wrench or a key left attached to a rotating part of the power tool may result in personal injury.

3.5 Do not overreach. Keep proper footing and balance at all times.

This enables better control of the power tool in unexpected situations.

3.6 Dress properly. Do not wear loose clothing or jewellery. Keep your hair, clothing and gloves away from moving parts.

Loose clothes, jewellery or long hair can be caught in moving parts.

3.7 If devices are provided for the connection of dust extraction and collection facilities, ensure these are connected and properly used.

Use of dust collection can reduce dust-related hazards.

4 Power tool use and care

4.1 Do not force the power tool.

Use the correct power tool for your application. The correct power tool will do the job better and safer at the rate for which it was designed.

4.2 Do not use the power tool if the switch does not turn it on and off.

Any power tool that cannot be controlled with the switch is dangerous and must be repaired.

4.3 Disconnect the plug from the power source and/or the battery pack from the power tool before making any adjustments, changing accessories, or storing power tools.

Such preventive safety measures reduce the risk of starting the power tool accidentally.

4.4 Store idle power tools out of the reach of children and do not allow persons unfamiliar with the power tool or these instructions to operate the power tool.

Power tool is dangerous in the hands of untrained users.

4.5 Maintain power tools. Check for misalignment or binding of moving parts, breakage of parts and any other condition that may affect the power tool's operation. If damaged, have the power tool repaired before use.

Many accidents are caused by poorly maintained power tools.

4.6 Keep cutting tools sharp and clean.

Properly maintained cutting tools with sharp cutting edges are less likely to bind and are easier to control.

4.7 Use the power tool, accessories and tool bits etc. in accordance with these instructions, taking into account the working conditions and the work to be performed.

Use of the power tool for operations different from those intended could result in a hazardous situation.

5 Battery tool use and care

5.1 Recharge only with the battery charger specified by the manufacturer.

A charger that is suitable for one type of battery pack may create a risk of fire when used with another battery pack.

5.2 Use power tools only with specifically designated battery packs.

Use of any other battery packs may create risk of injury and fire.

5.3 When battery pack is not in use, keep it away from other metal objects, like paper clips, coins, keys, nails, screws or other small metal objects, that can make a connection from one terminal to another.

Shorting the battery terminals together may cause burns or a fire.

5.4 Under abusive conditions, liquid may be ejected from the battery; avoid contact. Liquid ejected from battery may cause irritation or burns. If contact accidentally occurs, flush with water. If liquid contacts eyes, seek medical help.

Liquid ejected from the battery may cause irritation or burns.

6 Service

6.1 Have your power tool serviced by a qualified repair person using only identical replacement parts.

This will ensure that the safety of the power tool is maintained.

Grease injection injuries are a very serious injury. Hold the hose only in the area of the spring guard. Avoid accidental starting. Be sure switch is not depressed when inserting battery pack.

Replace the hose at the first sign of wear, kink or damage to the outside jacket.

Do not bend the hose so that it becomes kinked.

Do not overreach. Keep proper footing and balance at all times. Proper footing and balance enable better control of the tool in unexpected situations.

Use safety equipment. Always wear eye protection.

Dust mask, non-skid safety shoes, hard hat or hearing protection must be used for appropriate conditions.

The gun uses lubricants, that may be flammable and poisonous if ingested. Do not use gun near open flame or other fire hazards.

Greases are often marketed as high temperature because it must maintain their lubricating properties in hot areas, but the lubricants may be flammable if the temperature is too high. Please read all warnings on lubricants before using this gun. Do not use flammable greases with this grease gun.

Safety of others

This appliance is not intended for use by persons (including children) with reduced physical, sensory or mental capabilities, or lack of experience and knowledge, unless they have been given supervision or instruction concerning use of the appliance by a person responsible for their safety.

Children should be supervised to ensure that they do not play with the appliance.

Specific safety

Always wear eye protection.

The PowerLuber can generate up to 10,000 psi (689 bar). Use only Lincoln 1218, 1224, 1230 or 1236 outlet whip hoses.

⚠ WARNING

Do not use any hose that has not been approved by Lincoln. Extreme pressure may cause nozzle extension or whip hose to burst. Replace hose at first sign of wear, kinks, or damage to outside jacket.

Follow whip hose instructions and warnings. Failure to comply may result in serious injury or death.

⚠ WARNING

Grease gun can develop high pressure up to 10,000 psi (689 bar). Use safety glasses and gloves for protection during operation. Keep hands clear of exposed rubber portion of hose.

Residual risks

Additional residual risks may arise when using the tool which may not be included in the enclosed safety warnings. These risks can arise from misuse, prolonged use etc.

Even with the application of the relevant safety regulations and the implementation of safety devices, certain residual risks can not be avoided. These include:

- Injuries caused by touching any rotating/moving parts.
- Injuries caused when changing any parts, blades or accessories.
- Injuries caused by prolonged use of a tool. When using any tool for prolonged periods ensure you take regular breaks.
- Impairment of hearing.
- Health hazards caused by breathing dust developed when using your tool (example:- working with wood, especially oak, beech and MDF.)

Vibration

Declared vibration emission values stated in the technical data and the declaration of conformity have been measured in accordance with a standard test method provided by EN 60745 and may be used for comparing one tool with another. Declared vibration emission value may also be used in a preliminary assessment of exposure.

⚠ WARNING

The vibration emission value during actual use of the power tool can differ from the declared value depending on the ways in which the tool is used. The vibration level may increase above the level stated.

When assessing vibration exposure to determine safety measures required by 2002/44/EC to protect persons regularly using power tools in employment, an estimation of vibration exposure should consider, the actual conditions of use and the way the tool is used, including taking account of all parts of the operating cycle such as the times when the tool is switched off and when it is running idle in addition to the trigger time.

Labels on tool

The following symbols are shown on the tool.

⚠ WARNING



To reduce the risk of injury, the user must read the instruction manual.

Maintenance

The PowerLuber has been designed to operate over a long period of time with a minimum of maintenance. Continuous satisfactory operation depends upon proper tool care and regular cleaning.

Your charger does not require any maintenance apart from regular cleaning.

⚠ WARNING

Before performing any maintenance on the tool, remove the battery from the tool. Unplug the charger before cleaning it.

- Regularly clean the ventilation slots in your tool and charger using a soft brush or dry cloth.
- Regularly clean the motor housing using a damp cloth. Do not use any abrasive or solvent-based cleaner.
- Regularly open the chuck and tap it to remove any dust from the interior.

Protecting the environment



Separate collection. This product must not be disposed of with normal household waste.

Should you find one day that your Lincoln product needs replacement, or if it is of no further use to you, do not dispose of it with household waste. Make this product available for separate collection.



Separate collection of used products and packaging allows materials to be recycled and used again. Re-use of recycled materials helps prevent environmental pollution and reduces the demand for raw materials.

Local regulations may provide for separate collection of electrical products from the household, at municipal waste sites or by the retailer when you purchase a new product.



Run the battery down completely, then remove it from the tool. NiCd, NiMH and Li-Ion batteries are recyclable. Take them to any authorized repair agent or local recycling.

Safety instructions for battery and charger

Save these instructions

This manual contains important safety and operating instruction for the Lincoln model 1870E battery charger.

⚠ DANGER

Do not probe with conductive objects.
Do not charge damaged battery. Replace immediately.
Risk of Electric Shock 120 V AC or 230 V AC present at charger terminals.
Failure to comply may result in serious injury or death.

⚠ DANGER

Do not expose battery to spark or flame. Battery liquid may burn.
Do not splash or immerse in water or other liquids. This may cause premature cell failure.
Failure to comply may result in serious injury or death.

⚠ DANGER

Never attempt to open the battery pack for any reason. If the plastic housing of the battery pack breaks or cracks, return to a service center for recycling.
Failure to comply may result in serious injury or death.

Read all instructions

Batteries

- Never attempt to open for any reason.
- Do not expose the battery to water.
- Do not store in locations where the temperature may exceed 105 °F (40 °C) such as outside sheds or metal buildings in the summer.
- Charge only at ambient temperatures between 50 and 105 °F (10 and 40 °C).
- Charge only using the charger provided with the tool.
- When disposing of batteries, follow the instructions given in the section "Protecting the environment".



Do not attempt to charge damaged batteries.



Do not expose battery to fire.

Charger

- Before using a battery charger, read all instructions and cautionary markings on battery charger, battery pack, and product using battery.

⚠ CAUTION

Do not charge Lincoln model 1871 battery packs with any other charger.

To reduce risk of injury, Lincoln model 1870 or 1870E chargers should only be used to charge Lincoln battery pack model 1871. Other types of batteries may burst.

Failure to comply may result in serious personal injury

- Do not expose charger to rain, snow or frost.
- Do not abuse cord. Never carry charger by cord or pull on it to disconnect from receptacle. Pull by plug rather than cord when disconnecting charger. Have damaged or worn power cord and strain reliever replaced immediately. Do not attempt to repair power cord.
- Make sure cord is located so that it will not be stepped on, tripped over, or otherwise subjected to damage or stress.
- Do not use an extension cord unless absolutely necessary. Use of improper extension cord could result in a risk of fire and electric shock.
- Do not operate charger with damaged cord or plug. Replace immediately, to avoid a hazard. Do not attempt to repair power cord.
- Do not operate charger if it has received a sharp blow, been dropped, or otherwise damaged in any way, take it to a qualified service center.
- Do not disassemble charger or battery pack. Take it to a qualified service center when service or repair is required. Incorrect reassembly may result in risk of electrical shock or fire.
- Unplug charger from outlet before attempting any cleaning to reduce risk of electric shock.
- Charge the battery pack in a well ventilated place; do not cover the charger and battery with anything while charging.
- Do not store the charger or battery packs in locations where the temperature may reach or exceed 122 °F (50 °C) such as a

metal tool shed, or a car in the summer which can lead to deterioration of the storage battery.

- Do not charge battery pack when the temperature is below 40 °F (5 °C) or above 105 °F (40 °C). This is very important for proper operation.
- Do not incinerate battery pack. It can explode in a fire.
- Do not charge battery in damp or wet locations.
- Do not attempt to charge any other cordless tool or battery pack with the Lincoln model 1870 series charger.
- Do not short across the terminals of the battery pack. Extremely high temperatures could cause personal injury or fire.
- This appliance is not intended for use by persons (including children). Do not use this appliance if not experienced or have knowledge of how it operates.
- Dispose of expended batteries properly. The Lincoln model 1871 battery pack contains rechargeable, lithium-ion batteries. These batteries must be recycled or disposed of properly. Drop off expended battery packs at your local replacement battery retailer, or your recycling center.

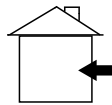

The charger is intended for indoor use only.



Read the instruction manual before use.

Electrical safety



Your charger is double insulated; therefore no ground wire is required. Always check that the mains voltage corresponds to the voltage on the rating plate. Never attempt to replace the charger unit with a regular mains plug.

- If the supply cord is damaged, it must be replaced by the manufacturer or an authorized Lincoln service center in order to avoid a hazard.

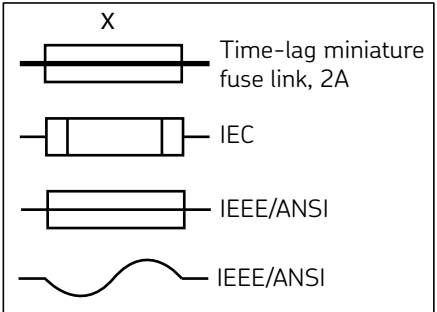

Tool use and care

Do not continue to hold down trigger if grease gun is stalled. This could damage the motor or cause fire.

Disconnect battery pack from tool before making any adjustments, changing accessories, or storing the tool. Such preventive safety measures reduce the risk of starting the tool accidentally.

Store the tools out of reach of children and other untrained persons. Tools are dangerous in the hands of untrained users.

If damaged, have the tool serviced before using. Many accidents are caused by poorly maintained tools.

Use only accessories that are recommended by Lincoln.

Only accessories that are capable of handling 10,000 psi (689 bar) should be used. Accessories that may be suitable for one tool may create a risk of injury when used on another tool.

Specifications

Basic PowerLuber model 1880

Operating power	14.5 to 20.5 V 
Maximum operating pressure	
Low output	6 000 psi (413 bar) ⁴⁾
High output	6 000 psi (413 bar)
Grease reservoir capacity	14.5 oz. (411 g)
Maximum peak pressure	10 000 psi (689 bar)
Operating temperature range	0 to 120 °F (-18 to 50 °C)
Operating current	4 A at 20 to 130 °F (-6 to 54 °C)
Rated current	5 A at 20 to 130 °F (-6 to 54 °C)
Lubricant (grease)	Up to NLGI #2
Grease output	
Low output (L)	3.5 oz./min. (0,103 l/min.)
High output (H)	5.5 oz./min. (0,162 l/min.)
Weight	6.5 lbs. (2,0 kg)
Accessories	
Battery li-ion	Model 1871
Output	20 V DC maximum
Capacity	2 500 mAh*
Battery charger	Model 1870
Charge time	1.5 hours
Input, vac (0.6 A)	120 v, 60 hz
Outlet hose	Model 1236
Pressure rating	10 000 psi (689 bar)
Length of the hose	36 in. (914 mm)

Note 1: Operating current and grease output data at 1 000 psi (69 bar).

Note 2: Declared vibration total value has been measured in accordance with a standard test method and may be used for comparing one tool with another and declared vibration total value may also be used in a preliminary assessment of exposure.

Note 3: Vibration emission during actual use of power tool can differ from declared total value depending on ways in which tool is used; and of need to identify safety measures to protect operator that are based on an estimation of exposure in actual conditions of use (taking account of all parts of operating cycle such as times when tool is switched off and when it is running idle in addition to trigger time).

Note 4: Gun will operate continuously under stated maximum operating pressure until motor's thermal protection activates. If maximum operating pressure is exceeded pump will momentarily stall and run intermittently until maximum peak pressure is reached.
* Indicates change.

Models	
Sales model	Components included
1880 1882	Grease gun with battery Grease gun with battery, charger and carrying case
1884	Grease gun with battery, extra battery, charger and carrying case.
1871	Battery pack
1236 5852 251-10124-7	Hose, 36 in. (914 mm) Coupler, midjet hydraulic Coupler (European)

General description

The Lincoln PowerLuber is a lithium-ion battery operated grease gun. The gun was developed for manual lubrication of grease points and includes a light emitting diode (LED) and electronic control center.

The PowerLuber is driven by a small, low voltage electric motor connected to a gear transmission. The rotary motion of the motor is converted into a reciprocating motion of the plunger using a yoke mechanism. The PowerLuber is a positive displacement single acting pump.

NOTE

Grease meter is very accurate and does not show output if prime is lost.

Change unit of measure to ounces or grams by holding button "1" for 15 seconds.

Control center

Technology incorporated into the 1880 series PowerLuber includes:

- Motor protection preventing overload due to excessive current draw. The display will flash red when this occurs.
- An LCD showing battery charge, pump speed and grease output.
- An illuminating LED light to help locate grease fittings in dim light.

Fig. 1

1880 Grease gun

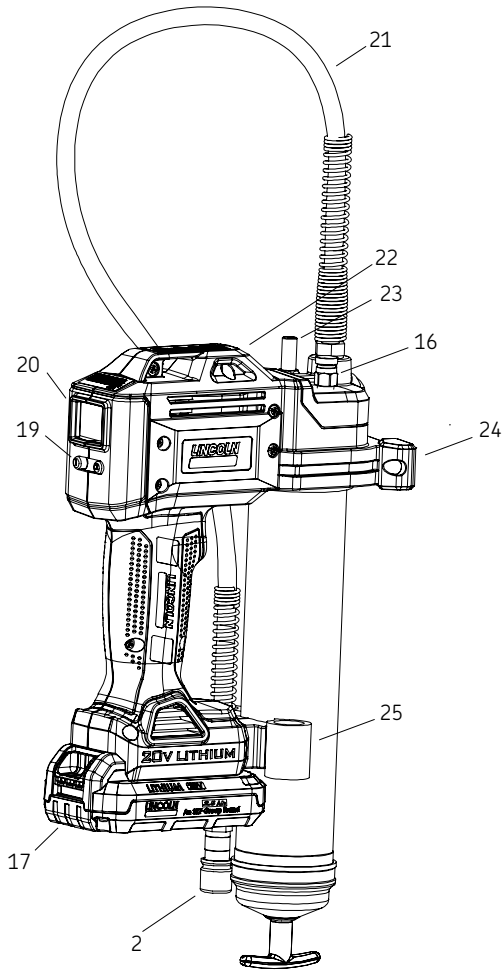

Inspection

Visually inspect for damaged, loose or missing parts. If equipment is worn or damaged, remove from service. Contact an authorized service center for damage assessment or repair.

Operation

Speed selection

Pressing button 2 switches the tool between high and low pump speed. The letter "L" or "H" will be displayed on the screen.

High delivers 5.5 ounces (0,162 l) per minute at 1,000 psi (68 bar) back pressure.

Low delivers 3.5 oz. (0, 103 l) per minute at 1,000 psi (68 bar) back pressure.

Motor speed increases automatically from "L" to "H" if back pressure exceeds 2,500 psi (172 bar).

LCD display and LED light

- Button number 1 turns on/off the LED
- Button number 1 turns on display
- The tool's trigger also turns on the LED and display
- The LCD and display will turn off after 30 seconds.

Parts

Item no.	Part
2	Coupler
16	Vent valve
17	Battery
19	Control button
20	Display
21	Hose
22	LED light
23	Bulk Valve
24	Support
25	Hose holder

Fig. 2

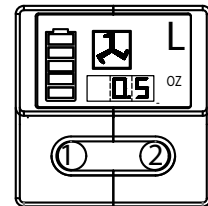

NOTE

Grease meter does not show output if prime is lost.

Change unit of measure to ounces or grams by holding button "1" for 15 seconds.

Grease flow monitoring

- LCD shows the output of grease delivered in ounces or grams.
- Change unit of measure to ounces or grams by holding button "1" for 15 seconds.
- Flow accuracy is +/- 10% at ambient temperature 32 °F (0 °C) -95 °F (+35 °C) and back pressure 0 psi - 4,000 psi (0 bar - 275 bar). Precise delivery is not measured outside these parameters.
- Meter accuracy is valid for use with NLGI 1 and 2 EP Lithium grease.
- Resolution of meter is .1 oz and 0.1 g.

Replace grease cartridge or refill tube

- 1 Prime the PowerLuber after each refill or grease cartridge change. To prime, operate the gun until grease flows from hose. Use vent valve (→ fig. 1, page 6) to expel air pockets.
- 2 Press button 1 for 3 seconds to clear display of previous reading.

Priming instructions

- 1 Open vent valve (→ fig. 1, page 6).

NOTE

Always open vent valve after replacing cartridge. This will allow air to escape from cartridge and prime grease gun.

Prime the PowerLuber after each refill or grease cartridge change.

- 2 Operate the gun until grease flows from the vent valve.
- 3 Close vent valve.
- 4 Press button "1" 3 seconds to clear display of previous reading.

Install grease cartridge

- 1 Unscrew the grease tube assembly from the PowerLuber.
- 2 Pull back on the follower handle and latch the follower rod groove into the slot on the tube cap.
- 3 Remove the plastic cap from the grease cartridge and insert cartridge into the container tube.
- 4 Remove the pull tab from the grease cartridge and screw the grease tube assembly into the pump assembly.
- 5 Thread grease tube assembly back onto the power head.
- 6 Release follower rod from slot. Purge air from pump. Refer to **page 8** for air purging instructions.
- 7 Reset display reading after purging air.
- 8 Refer to the section titled **LCD display and LED light**, page 6.

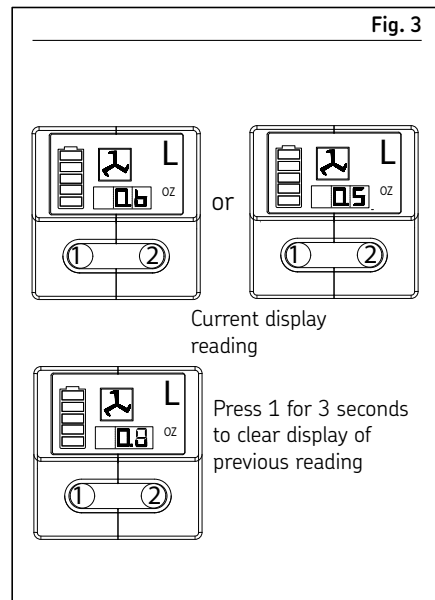

NOTE

Air pockets in the cartridge lubricant will cause the gun to lose its prime and will cause grease output measurements and cartridge level readings to be inaccurate.

To fill gun from bulk container

- 1 Remove pump assembly from grease tube assembly.
- 2 Pack lubricant into cavity of the pump assembly.
- 3 Insert the open end of the grease tube assembly into lubricant. Slowly pull the follower handle back while pushing the grease tube assembly deeper into the lubricant to prevent air pockets from being pulled into the grease tube.
- 4 With the follower rod fully extended, pull it sideways to latch the rod groove into the slot in the grease tube assembly cap.
- 5 Loosely assemble the pump to the grease tube assembly. Release the follower rod from the grease tube assembly cap and disengage the follower rod from the follower by rotating the follower handle.
- 6 Push the follower rod into the grease tube assembly.
- 7 Unscrew the grease tube assembly from the pump until lubricant oozes from the interface. Tighten grease tube assembly into the pump assembly.
- 8 Reset display reading after purging air.
- 9 Refer to the section titled **LCD display and LED light**, (→ page 6).

To fill gun with filler pump

- 1 Engage the follower rod with the follower by rotating the follower handle.
- 2 Insert the gun bulk fill valve into the filler pump socket.
- 3 Operate the filler pump to fill the container. When the follower rod groove is exposed, the grease tube assembly is filled. The follower rod will be extended approximately 8 in. (20 cm). Do not overfill!
- 4 Disengage the follower rod from the follower by rotating the follower handle.
- 5 Push the follower rod into the grease tube assembly.
- 6 Reset display reading after purging air.

NOTE

Remove air pocket! Air pocket at grease inlet will prevent grease from being pumped. Unscrew the vent valve three to four turns to remove small air pockets trapped in this area. If the air pocket is substantial and no grease flows from coupler after trigger is pulled for 15 seconds, refer to the following steps.

To expel air pockets (air purging)

- 1 Withdraw the follower rod from the grease tube assembly cap and engage it with the follower by rotating the follower handle.
- 2 Unscrew the plug of vent valve 3 to 4 turns. Exert force on the follower handle until grease flows through the small hole in the side of the vent valve.
- 3 Tighten the vent valve.
- 4 Pull the trigger in short bursts to operate gun until trapped air is expelled. Disengage the follower rod from the follower by rotating the follower handle. Push the follower rod into the grease tube assembly.
- 5 If step 2 fails, unscrew the grease tube assembly 3 turns from the pump assembly.
- 6 Exert force on the follower handle until lubricant oozes from the grease tube assembly and pump assembly interface.
- 7 Retighten grease tube into the pump assembly. Disengage the follower rod from the follower by rotating the follower handle. Push the follower rod into the grease tube assembly.

Charger operation

Charging battery pack

Before using your PowerLuber for the first time, the battery pack should be fully charged. If the battery pack is installed in the PowerLuber, remove it and follow charging procedure below.

Lincoln chargers are designed to charge Lincoln lithium-ion batteries in 30 to 90 minutes depending on the battery's state of charge and temperature.

Charging procedure

Make sure power circuit voltage is the same as that shown on the charger specification plate.

- 1 Plug the charger into an appropriate outlet before inserting battery pack.
- 2 Insert the battery pack into the charger.
The green (charging) light will blink continuously indicating that the charging process has started.
- 3 The completion of charge will be indicated by the green light remaining on continuously. The pack is fully charged and may be used at this time.
- 4 Disconnect charger from power source when not in use.

⚠ CAUTION

Do not probe with conductive objects. 120/230 V AC present at charging terminals. Failure to comply may result in death or personal injury.

Indicator light operation

- The charge is complete (solid green).
- Battery is charging (flashing green).
- Red, at a fast rate. Replace battery.
- Charger detected a weak or damaged battery. Stop charging battery. Hot/cold pack delay. Charger detected a battery that is excessively hot or cold. It automatically starts a hot/cold pack delay, suspending charging until temperature of battery has normalized. After this, charger automatically switches to battery charging mode.

NOTE

Battery temperature will increase during and shortly after use. Batteries may not accept a full charge if they are charged immediately after use. Allow the battery pack to cool to room temperature before charging for best results.

NOTE

Vent slots in top and bottom of charger must not be obstructed.

Do not charge battery when temperature is below 40 °F (5 °C) or above 104 °F (40 °C).

Important charging notices

Longest life and best performance can be obtained if the battery is charged when the air temperature is between 65 and 75 °F (18 and 24 °C). Do not charge the battery in an air temperature below 40 °F (5 °C) or above 105 °F (41 °C). This is important and will prevent serious damage to the battery.

- 1 The charger and battery may become warm to the touch while charging. This is a normal condition, and does not indicate a problem.
- 2 If the battery does not charge properly:
 - 2.1 Check current at receptacle by plugging in a lamp or other appliance.
 - 2.2 Check to see if the receptacle is connected to a light switch which turns power off when you turn out the lights.
 - 2.3 Move charger and battery to a location where the surrounding air temperature is between approximately 65 and 75 °F (18 and 24 °C).
 - 2.4 If charging problems persist, take the tool, battery and charger to your local service center.
- 3 The battery should be recharged when it fails to produce sufficient power on jobs. Do not continue to use under these conditions. Follow the charging procedure. You may also charge a partially used pack whenever you desire with no adverse affect on the battery.

- 4 Under certain conditions, with the charger plugged into the power supply, the exposed charging contacts of the charger can be shorted by foreign material. Foreign materials of a conductive nature such as, but not limited to, steel wool, aluminum foil, or any buildup of metallic particles should be kept away from charger cavities. Always unplug the charger from the power supply when there is no battery in the cavity. Unplug charger before attempting to clean.
- 5 Do not freeze or immerse charger in water or any other liquid.

⚠ WARNING

Do not allow any liquid to get inside charger. Electric shock may result.

To facilitate cooling of battery pack after use, avoid placing charger or battery pack in a warm environment such as a metal shed or an uninsulated trailer.

Failure to comply may result in serious injury or death.

Fig. 4

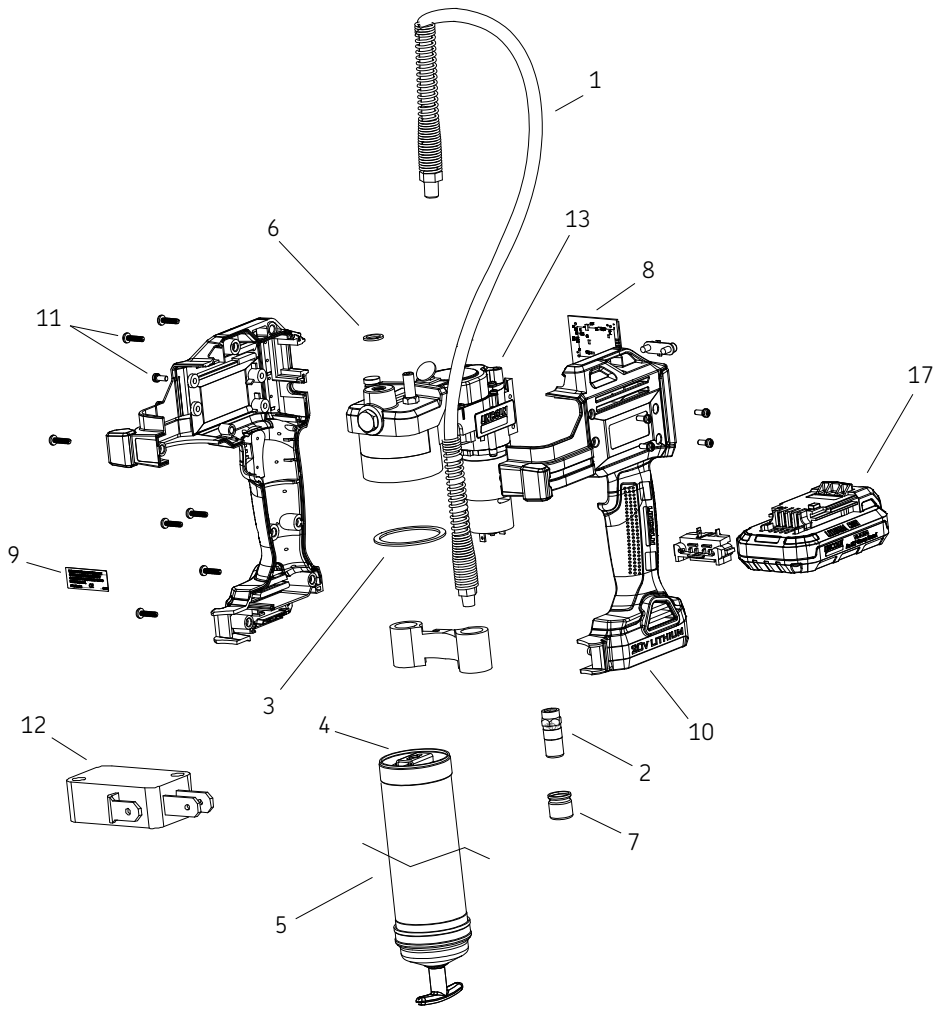

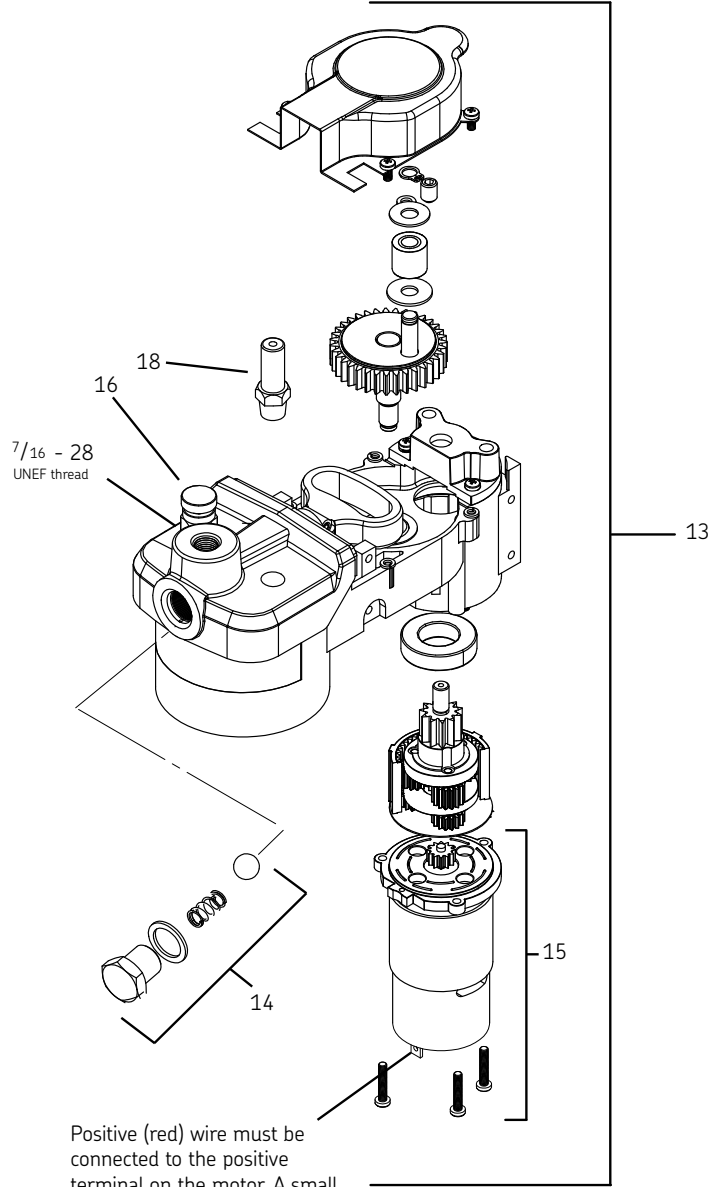

Positive (red) wire must be connected to the positive terminal on the motor. A small plastic dot identifies the positive terminal.

Service parts list

Item	Description	Part number
1	Flexible hose 36 in. (914 mm) with gasket	1236
2	Coupler	5852
3	Packing	34793
4	Follower assembly kit	272072
5	Grease tube assembly	271882
6	Gasket kit (hose)	260322*
7	Coupler cap kit	286419
8	Electrical components kit	280067
9	Decal kit	280068
10	Handle with electrical component kit	280069
11	Handle with screw kit	280070
12	Switch kit	280071
13	Pump assembly kit	280072
14	Check valve kit	280073
15	Motor with adapter kit	280074
16	Vent valve kit	286315
17	Battery 20 V (lithium)	1871
18	Filler nipple	91108
Not shown	Charger (lithium)	1870
Not shown	Strap	1414
Not shown	Case kit	280085

* Indicates change.

Troubleshooting

Condition	Possible cause	Corrective action
Motor fails to run.	Battery needs charging.	Recharge battery.
	Faulty wiring to motor.	Remove battery, disassemble handle and check wiring for loose connection.
PowerLuber fails to dispense grease.	Grease tube assembly is out of grease.	Check that grease tube assembly has grease.
	Loss of prime.	Repeat priming operation.
	Ball check (14) is not functioning.	Remove ball check (14) , clean and inspect ball seat area.
PowerLuber continues to lose prime.	Air may be trapped in several locations in container after bulk filling.	Empty grease tube assembly, refill and repeat priming instructions.
	Follower may be binding in grease tube assembly.	Replace grease tube assembly (5) . Disassemble grease tube assembly and clean. Be sure that follower has properly entered the grease cartridge. or Verify that the follower is not caught on the rim of the grease cartridge.
	Check ball seat and check ball dirty.	Clean check ball and check ball seat.
Battery fails to take a charge.	Charger may not have power.	Check that receptacle has power.
	Battery may be bad.	Replace battery.

We declare that the model of the battery charger in version supplied by us complies with the requirements of UL 1012, Standard for Power Units Other Than Class 2 and Canadian Standard for battery chargers. CAN/ CSA-C22.2 No. 107.2-01



St. Louis, MO, June 2017
Bob Hoefler, Director, Product Development
and Product Engineering

This page left intentionally blank

Warranty

The instructions do not contain any information on the warranty.
This can be found in the General Conditions of Sales, available at:
www.lincolnindustrial.com/technicalservice or www.skf.com/lubrication.

skf.com | lincolnindustrial.com

© SKF and Lincoln are registered trademarks of the SKF Group.

© SKF Group 2020
The contents of this publication are the copyright of the publisher and may not be reproduced (even extracts) unless prior written permission is granted. Every care has been taken to ensure the accuracy of the information contained in this publication but no liability can be accepted for any loss or damage whether direct, indirect or consequential arising out of the use of the information contained herein.

June 2020 · Form 423077 Version 3