

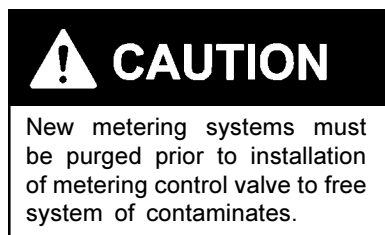

Safety Instructions

To ensure safe and efficient operation, it is essential to read each of these warnings and precautions and to carefully follow all instructions listed in this manual.

1. Improper use or installation of the product can cause serious bodily injury or death.
2. DO NOT smoke near meter or use meter near an open flame when measuring flammable fluids. Fire could result.
3. Do not exceed 50 PSI/3.5 Bar Line pressure.
4. CAUTION: Do not install additional foot valve or check valve during installation without pressure relief valve. Cracking may result.
5. This product should not be used for fluid transfer into aircraft.
6. This product is not suited for use with fluids for human consumption.



GENERAL DESCRIPTION

The Lincoln Series 900 Meter is a rotating disc flow meter. The meter uses wheel counters for registering either U.S. Gallons or liters. The U.S. Gallon meter has three unit wheels and a tenth wheel, which can be reset to zero. Its totalizer has eight unit wheels.

Fluid Compatibility

The 961 and 964 are compatible with the following fluids:

- Diesel Fuel, Gasoline, Kerosene, Mineral Spirits, Heptane and Hexane.

The 961 and 964 are NOT compatible with the following fluids:

- Bleach, Hydrochloric Acid, Ink, Sulfuric Acid and Salt Water.

If in doubt about compatibility of a specific fluid, contact supplier of fluid to check for any adverse reactions to the wetted materials shown on the parts list.

SAFETY

The safety of Lincoln Series 900 meters is proven by their listing with:



Underwriters Laboratories Inc. a nationally recognized independent organization for testing of Products to ensure public safety.



Canadian Standards Association, a Canadian Organization for testing of products to ensure public safety.

Technical Information

Design Features:

- 1" NPT Female inlet and outlet ports
- 6 to 40 GPM/23 to 151 LPM flow rate
- $\pm 2\%$ accuracy
- 50 PSI maximum pressure
- Measures fluids with temperatures from -15°F (-26°C) to 150°F (66°C)
- Weatherproof, corrosion resistant
- Large $11/16"$ figures with zero reset
- Measures flow to 1,000 gallons in 1/10 increments.
- Easy to read totalizer registers to 1,000,000 gallons
- Compact design: $8-1/2" \times 6-1/2" \times 5-1/2"$ (22 cm x 17 cm x 14 cm)
- Large reset knob
- Self-Lubricating
- Not for resale use
- Maximum viscosity of fluid: diesel fuel
- Pressure drop* through meters:
 - 10 GPM (38 LPM) - 1 psid (0.07 bar)
 - 20 GPM (76 LPM) - 2.5 psid (0.17 bar)
 - 40 GPM (151 LPM) - 9 psid (0.61 bar)

* Nominal data based on mineral spirits. Actual pressure drop may vary.

Models 961 & 964

Volume Meters

Series "D"



INSTALLATION

Meters are furnished for vertical piping, up to down flow (horizontal piping; left to right flow) unless otherwise specified. Flow ports can be changed to any of four positions for horizontal or vertical piping and for either direction of flow.

1. Determine direction for fluid to flow.
2. Install meter observing directional arrow on casting.
3. Remove four screws (item 28).
4. Rotate meter cover assembly (item 37) to desired orientation.
5. Replace four screws.

ASSEMBLY & DISASSEMBLY

Meter consists of a chamber housing, measuring chamber, gear train, counter assembly and cover. Meter can be completely disassembled without disturbing piping, or meter can be partially disassembled as required.

Counter Assembly

For access to counter assembly, remove reset knob (item 15) by grasping edges and pulling firmly. Knob is held in place by a spring clip. Loosen two screws (item 14) and lift bezel (item 11) off. Remove two screws (item 12) to detach counter face (item 13). Remove two screws (item 9) to extract counter (item 10). Reassemble by reversing procedure.

Meter Chamber Assembly

To expose meter chamber assembly, gear train and seal, remove four screws (item 28). Meter chamber assembly consists of upper and lower chambers, a rotating disc and four screws. Meter chamber assembly (item 3) can be dislodged by removing four screws (item 5). Reassemble by reversing procedure.

If replacement of any components of the meter chamber assembly is required, the complete assembly must be replaced due to the precise method of its construction. This assures a proper fit and a correctly operating chamber.

Gear Train and Seal

To disassemble gear train and seal, remove two screws (item 8) and gear frame (item 6). Remove cluster gear (item 18), washer (item 19), and shaft (item 17). Remove drive gear (item 24) and washers (item 23) by rotating and pulling drive gear. Remove O-Ring seal (item 25).

When reassembling seal, lubricate O-Ring with oil or petroleum jelly and replace in cover. Place washer on drive gear shaft. Rotate and push shaft through O-Ring and cover carefully to prevent damage to O-Ring. Shaft must then be guided into pinion bevel (item 27) if counter has not been removed. Replace remaining parts to complete assembly by reversing disassembly procedure.

OPERATING INSTRUCTIONS

For accurate measurement and to prevent meter damage, meter and piping must always be filled with liquid and free of air. Meter should be calibrated per instructions in this manual prior to its use.

1. Reset meter to "0".
2. Meter is ready for use.

MAINTENANCE

Meter should operate maintenance free. However, certain liquids can dry out while in meter housing, causing the meter to stop. If this happens, meter should be thoroughly cleaned (see instructions below).

Cleaning Instructions:

Run a flushing fluid through meter. For a more thorough cleaning, disassemble meter per "Assembly & Disassembly" section, "Meter Chamber Assembly" subsection. Rinse all meter components. Recalibrate meter following calibration instructions.

Storage:

If meter is to be stored for a period of time, clean thoroughly. This will help protect meter from damage.

REPAIR

Meters needing repair should be taken to an authorized repair shop or returned to factory for service. Meters must be thoroughly triple-rinsed before being taken in for repair.

PRIOR TO SERVICE, ADHERE TO THE FOLLOWING INSTRUCTIONS:

If meter was used for a fluid other than a petroleum product, it must be triple-rinsed and accompanied by a note indicating the chemicals that have been pumped through the unit. Meters not adhering to these specifications may be refused service at either the repair shop or at the factory.

WHEN ORDERING REPAIR PARTS, BE SURE TO GIVE REPLACEMENT PART NUMBER, DATE OF MANUFACTURE AND METER SERIES NUMBER. THIS WILL ENSURE THAT THE CORRECT REPLACEMENT PART IS SUPPLIED.

**Models 961 & 964
Volume Meters
Series "D"**



CALIBRATION

The Lincoln Series 900 meters can be calibrated for either U.S. gallons or liters. Calibration is required upon installation, after disassembly, after significant wear or when metering a different viscosity fluid. Depending on the model, Series 900 meters are calibrated at the factory metering gasoline in either U.S. gallons or liters. Calibration must be done between 6 and 40 GPM (23 and 151 LPM).

Meter calibration can be easily changed by following the calibration procedure listed below. A proving container or a container of KNOWN volume will be needed for the calibration procedure. It is recommended that the container's volume be at least five times larger than the unit of calibration. For example, a five-gallon container should be used when calibrating for gallons.

Procedure for Calibration:

1. Fill container to a known volume.
2. If meter amount is incorrect, turn calibration screw (item 31) counterclockwise for less liquid, or clockwise for more liquid.
3. Repeat step 2 until calibration is acceptable.

TROUBLESHOOTING GUIDE

PROBLEM	POSSIBLE CAUSE	SOLUTION
Counter reading high or low.	Calibration off	Recalibrate Meter
	Air in product	Find and repair air leaks in system.
	Measuring chamber or gears sticking	Clean or replace internal metering components.
Shaft seal leakage.	Dirty seal	Clean O-Ring seals and seat area.
	Bad seal	Replace seals.
Gasket Leakage.	Loose joints	Tighten joints
	Dirty gasket	Clean gasket and seat area.
	Bad gasket	Replace gasket.
Low Flow Capacity.	Clogged meter chamber (or strainer).	Clean meter chamber.

**Models 961 & 964
Volume Meters
Series "D"**

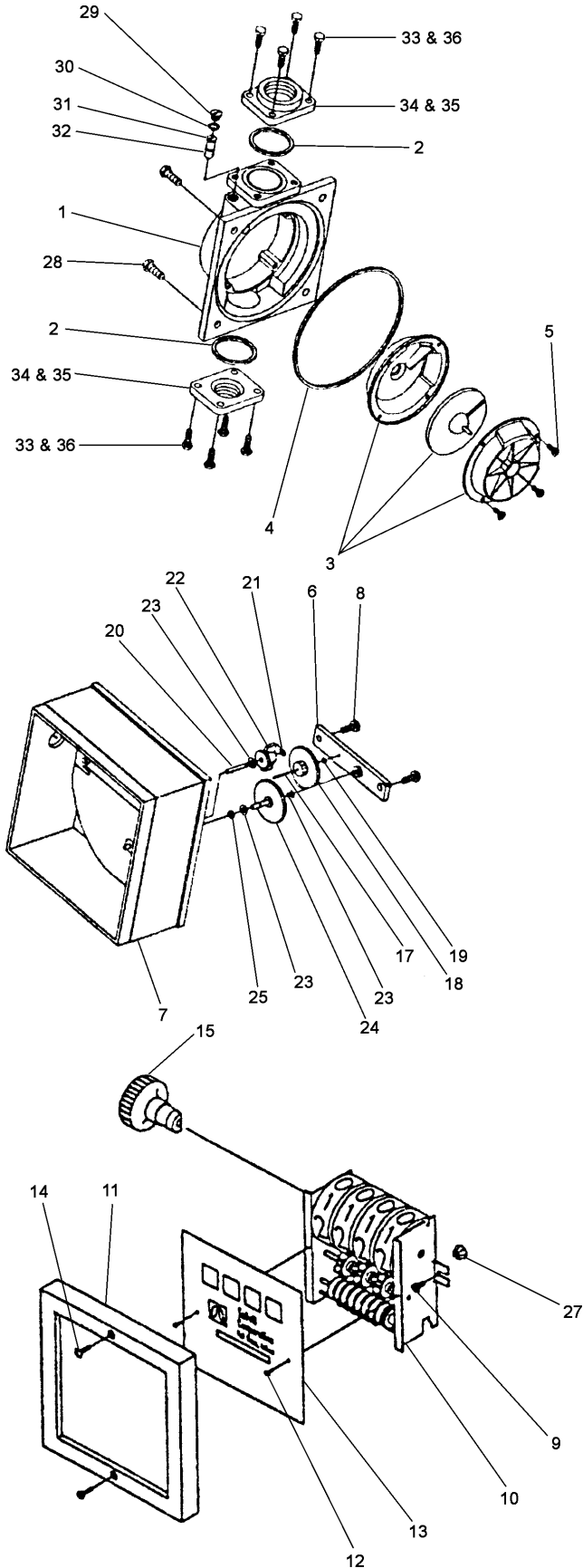

SERVICE PARTS

ITEM NO.	PART NO.	DESCRIPTION	QTY
1	271945	Meter Housing	1
2	271946	Inlet/Outlet Gasket	2
3	271947	Meter Chamber Assembly	1
4	271948	Cover Gasket	1
5	271949	#10-32 x 1/2 PHMS, ACR II, T	4
6	271950	Gear Frame	1
7	271951	Meter Cover (Includes Item 20)	1
8	271952	#12-1/2 PHMS< Type AB	2
9	271953	#8-32 x 5/16 PHMS < ACR II, TT	2
10	271954	Counter Assembly - U.S. Gallon	1
	271955	Counter Assembly - Liter	Opt.
11	271956	Bezel	1
12	271957	#4-40 x 1/4 PHMS	2
13	271958	Counter Face	1
	271959	Counter Face - Liter	Opt.
14	271960	#8 x 1/2 OHMS - Type B	2
15	271961	Knob	1
17	271962	Shaft Cluster Gear	1
18	271963	Cluster Gear - U.S. Gallon	1
	271964	Cluster Gear - Liter	Opt.
19	271965	Washer	1
20	271966	Driver Pinion Shaft (Included w ith Item 7)	1
21	271967	Retaining Ring	1
22	271968	Driver Pinion Shaft (Included w ith Item 7)	1
23	271969	Washer	3
24	271970	Drive Gear - U.S. Gallon	1
	271971	Drive Gear - Liter	Opt.
25	271972	O-Ring (5-106)	1
27	271973	Pinion Bevel	1
28	271974	5/16 x 18 x 7/8 HHCS	4
29	271975	Seal Screw	1
30	271976	O-Ring (-012)	1
31	271977	Adjustment Screw (Includes item 32)	1
32	271983	O-Ring (-010)	1
33	271978	1/4-20 x 3/4 HHCS (1" Meters)	8
34	271979	1" Meter Flange	2
37	271980	Meter Cover Assembly - U.S. Gallon	1
	271981	Meter Cover Assembly - Liter	Opt.

900 SERIES REPAIR PARTS KITS

271905	Meter Repair Kit, U.S. Gallon (Standard Seals) Includes items 2-4, 6, 17-19, 21-25, 27, 30, 32
271906	Meter Repair Kit, Liter (Standard Seals) Includes items 2-4, 6, 17-19, 21-25, 27, 30, 32