

**CAUTION**

Before meter can be placed in service "After Repair", Meter must be tested and approved in accordance with U.S. Government's Weights and Measures Standards.

**CAUTION**

New metering systems must be purged prior to installation of metering control valve to free system of contaminates.

**IMPORTANT NOTE:**

The automatic nozzle requires 60 PSI to open and function properly. A pump exceeding 60 PSI is required for adequate flow and proper operation. A pump ratio of at least 3:1 is recommended.

### OPERATION

The meter can handle petroleum products such as automatic transmission fluid, S.A.E. 5 to 50 weight motor oil, S.A.E. 80 to 240 weight gear oil and antifreeze fluid (ethylene glycol). The meter can be locked in the on position by engaging the trigger lock, to release the lock the trigger must be depressed thus releasing the lock. Before each use reset the meter by rotating the indicator knob counterclockwise to zero.

### SPECIFICATIONS:

Dial Capacity	32 Ounces - 16 Quarts
Totalizer	Quarts
Flow Max.	4 Gallons per min. (15 liters per min.)
Flow Min.	0.4 Gallons per min. (1.5 Liters per min.)
Operating Pressure Max.	1000 PSI (70 Bar)
Operating Temp. Max.	110° F (45° C)
Accuracy	+/- 0.65%
Weight	3.3 Lbs. (1.5 Kg.)
Meter Inlet & Outlet Thds.	1/2 NPTF

© Indicates change

Americas:  
One Lincoln Way  
St. Louis, MO 63120-1578  
USA  
Phone +1.314.679.4200  
Fax +1.800.424.5359

Europe/Africa:  
Heinrich-Hertz-Str 2-8  
D-69183 Walldorf  
Germany  
Phone +49.6227.33.0  
Fax +49.6227.33.259

Asia/Pacific:  
25 Int'l Business Park  
#01-65 German Centre  
Singapore 609916  
Phone +65.562.7960  
Fax +65.562.9967

© Copyright 2002  
Printed in USA

www.lincolnindustrial.com

Inner circle indexes in full quart to sixteen quarts.  
Outer circle indexes in fourths of one quart.

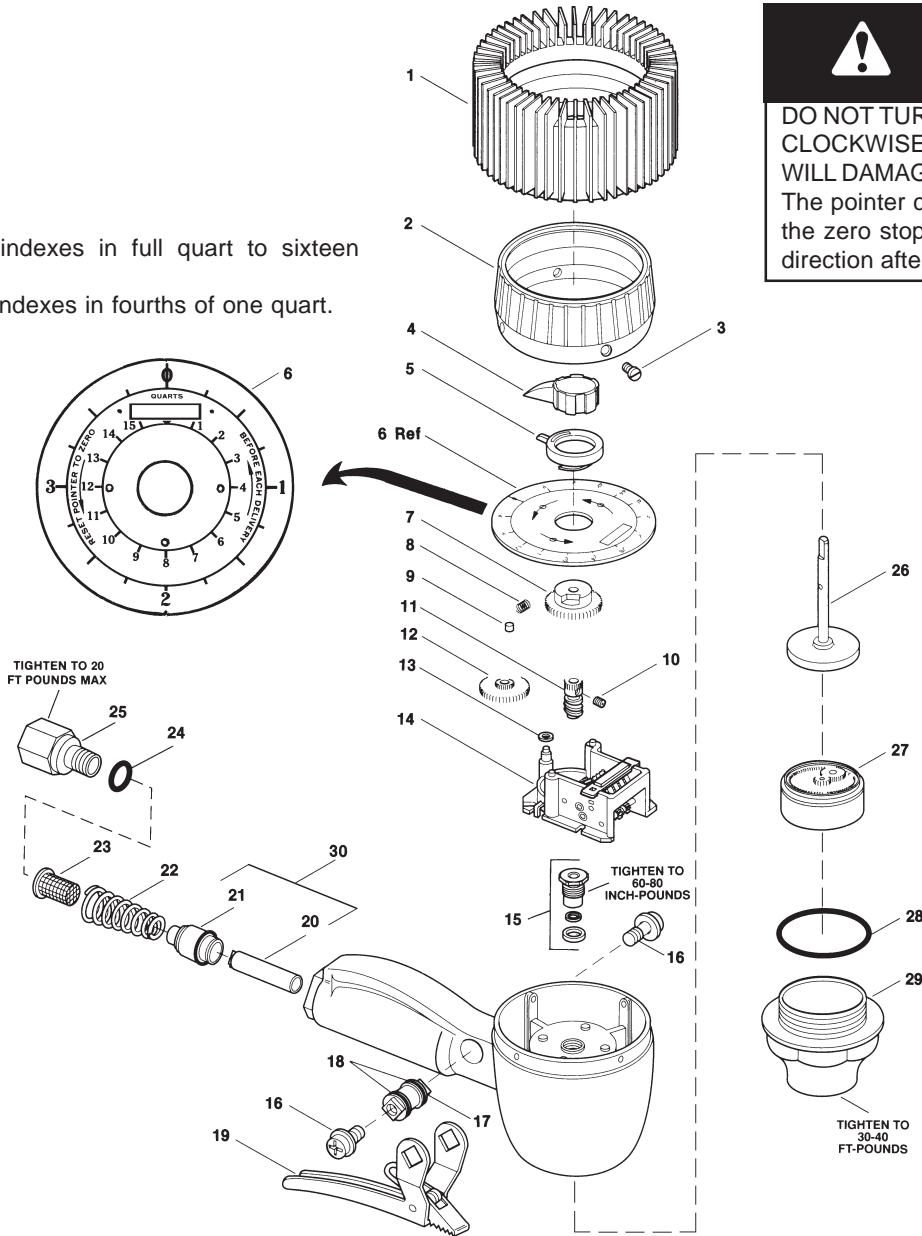

**Service Parts**

ITEM	DESCRIPTION	Part No.	ITEM	DESCRIPTION	Part No.
1	*Shroud Protector	242911	16	Screw	68410-2 (2)
2	Shroud	68410-12	17	Cam	68410-5
3	Shroud screw	66871 -5 (4)	18	O-ring	68410-4 (2)
4	Knob assembly	242912	19	Valve trigger assembly	68410-1
5	Inner circle pointer	66871-53	20	**Valve sleeve assembly	
6	Dial assembly	68410-26	21	**Valve seat assembly	
7	Inner circle pointer cam	66871-50	22	Spring	69304-3
8	Clutch spring	66871-3	23	Screen	68410-27
9	Clutch roller	66871-4	24	O-ring	243176
10	Set screw	50541	25	Adapter	243175
11	Upper driving pawl worm gear	66871 -54	26	Upper driving pawl gear assembly	66871-111
12	Inner circle pointer gear	66871-17	27	Chamber & piston assembly	68410-15
13	Spacer	69304-23	28	Housing cap gasket	66871-12
14	Register assembly	69795-3	29	Housing cap	68410-14
15	Packing kit	237388	30	Valve Assembly (Buna-N)	271700

Quantity

\* May be purchased separately

\*\* See valve assembly item 30