

OPERATING INSTRUCTIONS PARTS AND SERVICE

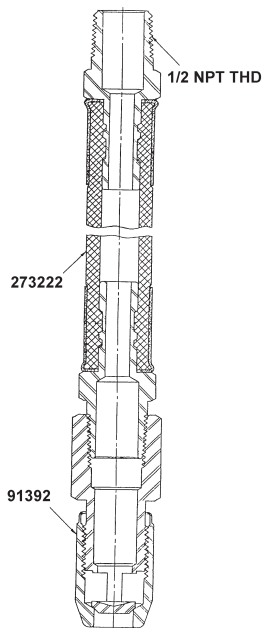

82642
NON-DRIP NOZZLE
Used on Model 769

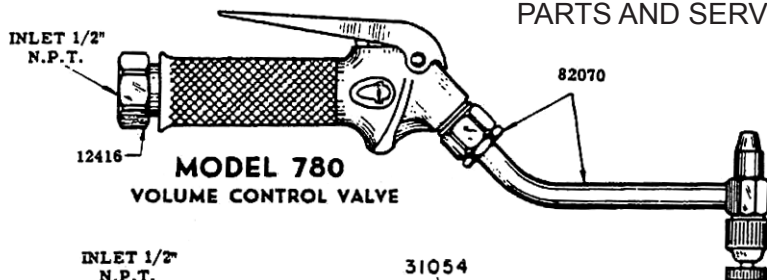

MODEL 780
VOLUME CONTROL VALVE



MODEL 779
VOLUME CONTROL VALVE

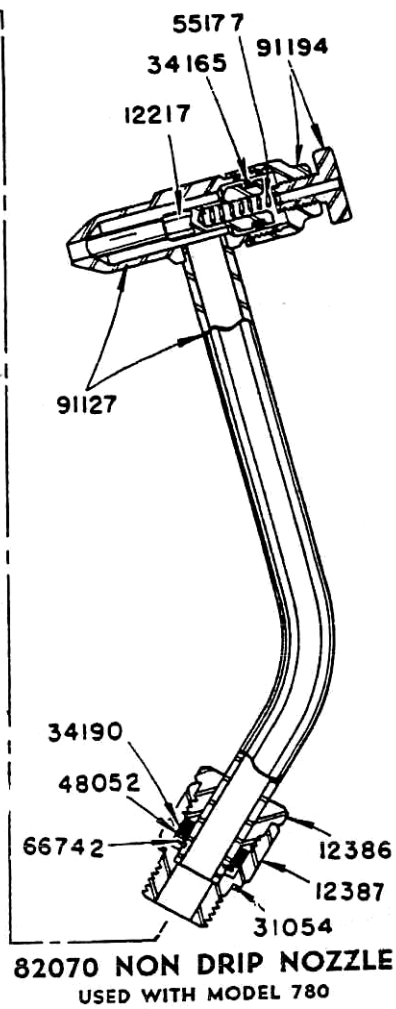
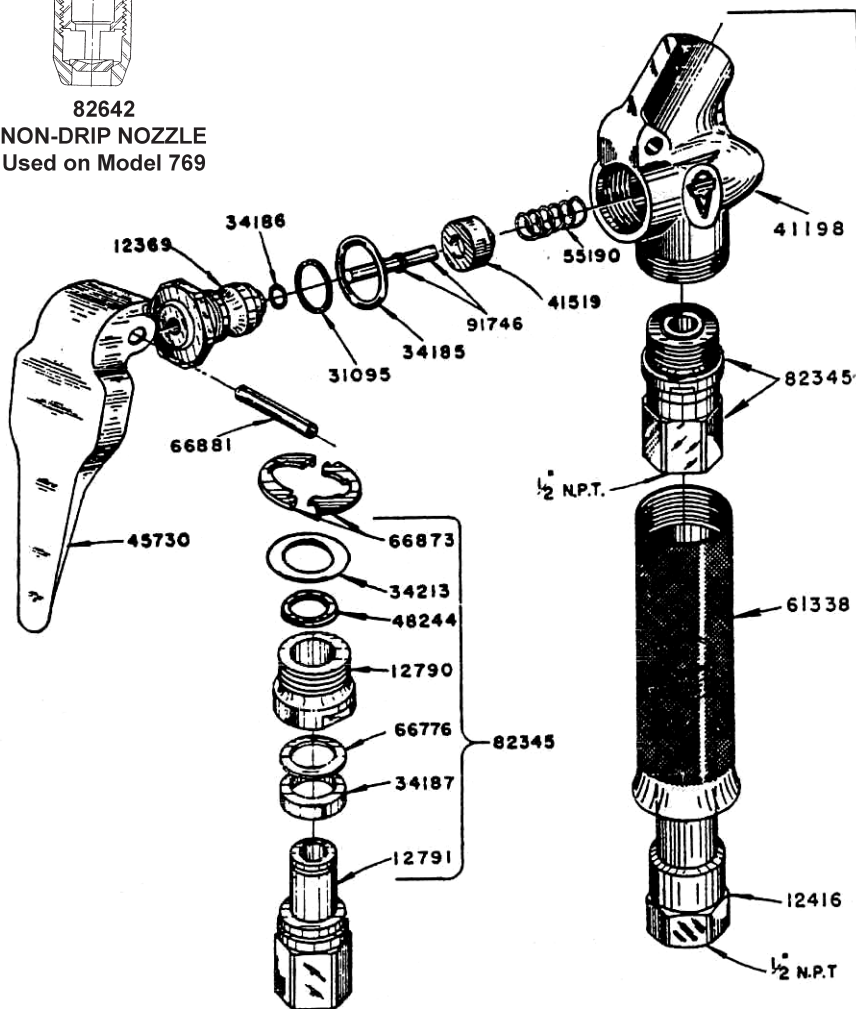

82070 NON DRIP NOZZLE
USED WITH MODEL 780

WARNING

Systems which will be dispensing fluids under pressure may need to be protected by using a thermal relief kit, which will safely limit the pressures caused by thermal expansion. Please contact your local Lincoln distributor and refer to Service Page Section K5, Page 31 for more details. Failure to include thermal relief protection may cause damage not covered under Lincoln's warranty policy.

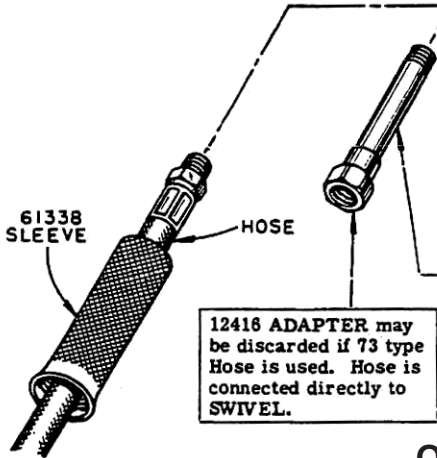
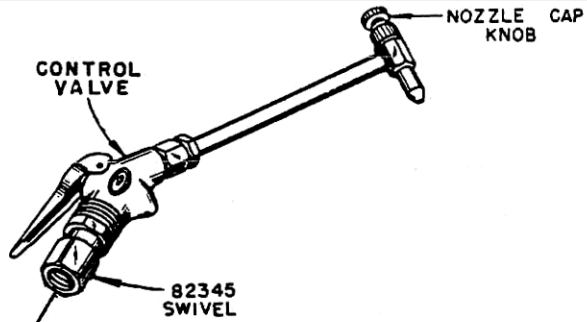

When CONTROL VALVE is used with CEILING LUBREELS the 12416 ADAPTER is to be discarded. Insert the Hose through the 61338 SLEEVE and assemble to the 82345 SWIVEL. SLEEVE is then slid over the hose and assembled to the valve casting.

When the delivery Hose is of a size that will not fit into the SLEEVE the 12416 ADAPTER is used.

The 12416 ADAPTER is required for FLOOR TYPE LUBREELS. The GLAND BUSHING of these lubreels assemble into the 12416 ADAPTER.

12416 ADAPTER may be discarded if 73 type Hose is used. Hose is connected directly to SWIVEL.

© Indicates change

OPERATION

The CONTROL VALVE is designed to allow the operator complete control of the volume of lubricant being dispensed. First unscrew the NOZZLE CAP KNOB three or four full revolutions. A slight compression of the VALVE HANDLE- will allow a small volume of lubricant to pass through the CONTROL VALVE, and NOZZLE. As the HANDLE is further compressed the lubricant volume will increase. When the VALVE HANDLE is released a PLUNGER in the NOZZLE TIP prevents the lubricant from draining out of the hose extension. The NOZZLE should always be dosed when the CONTROL VALVE is not being used. To dose NOZZLE turn the NOZZLE CAP KNOB dock-wise and tighten by hand If lubricant continues to flow from NOZZLE TIP after the VALVE HANDLE is released:

- Lubricant is by-passing the 41519 CHECK SEAT. H sealing surface is cut or other wise damaged, replace the 41519 CHECK SEAT. To remove the VALVE HANDLE use a slender punch to drive the 66881 ROLL PIN out of the HANDLE and VALVE CASTING.
- PLUNGER in NOZZLE TIP or seat for PLUNGER In NOZZLE TIP is worn, pitted or otherwise damaged. Tighten and retighten NOZZLE CAP KNOB two or three times with pliers to reseat plunger. IMPORTANT: After reseating PLUNGER remove and Inspect 41519 CHECK SEAT. Replace if damaged. . CHECK SEAT should hold the lubricant pressure back from NOZZLE as purpose of NOZZLE is not to stop flow of lubricant when under pressure.

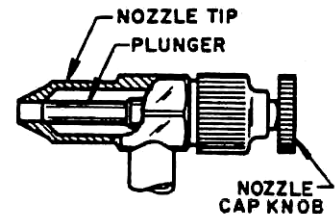

REPAIR PARTS LIST

PART NO.	DESCRIPTION	PART NO.	DESCRIPTION	PART NO.	DESCRIPTION
12217	Plunger	34186	"O" Ring Packing	66742-1	Retaining Ring
12369	Gland Nut	34187	Packing	66776	Spring Washer
12386	Swivel Nut	34190	Swivel Packing	66873-1	Truarc Retaining Ring
12387	Sir. Swivel Body	34213	"O" Ring Packing	66881	Roll Pin
12416	Adapter	41198	Valve Body	82070	Non Drip Nozzle Assembly
12418	Adapter	41519	Check	82345	Swivel Assembly
12790	Swivel Adapter	45730	Handle	91127	Nozzle Body Assembly
12791	Swivel Stud	48052	Plunger Packing Washer	91194	Cap Assembly
31054	Gasket	48244	Washer	91746	Plunger Assembly
31095	Gasket	55177	Spring	91392	Nozzle
34165	"O" Ring	55190	Spring	273222	Hose Assembly
34185	"O" Ring Packing	61338	Valve Sleeve		