



MODEL 600203 MINIATURE AIR LUBRICATOR

OWNER/OPERATORE RESPONSIBILITY

It is the owner/operatore responsibility to properly use and maintain this equipment. The instructions and warning contained in this manual shall be read and understood by the ower/operatore prior to operating this equipment.

If an owner/operatore does not understand English, the contents of this manual shall be explained in the owner/operators native language to assure that the owner/operator comprehends.

The owner/operator shall retain this manual for future reference to important warnings, operating and maintenance instructions.

SPECIFICATIONS

Bowl Capacity	1 ounce
Minimum Flow for Lubrication	0.5 SCFM at 100 PSIG
Port Threads	1/4 Inch
Pressure & Temperature Ratings - Polycarbonate Bowl	0 to 150 PSIG (0 to 10.3 bar)
	32°F to 125°F (0°C to 52°C)

CONSTRUCTION

Body	Aluminum
Bowl	Polycarbonate
Drain	Manual Twist Brass
Seals	Nitrile
Sight Dome	Polyurethane

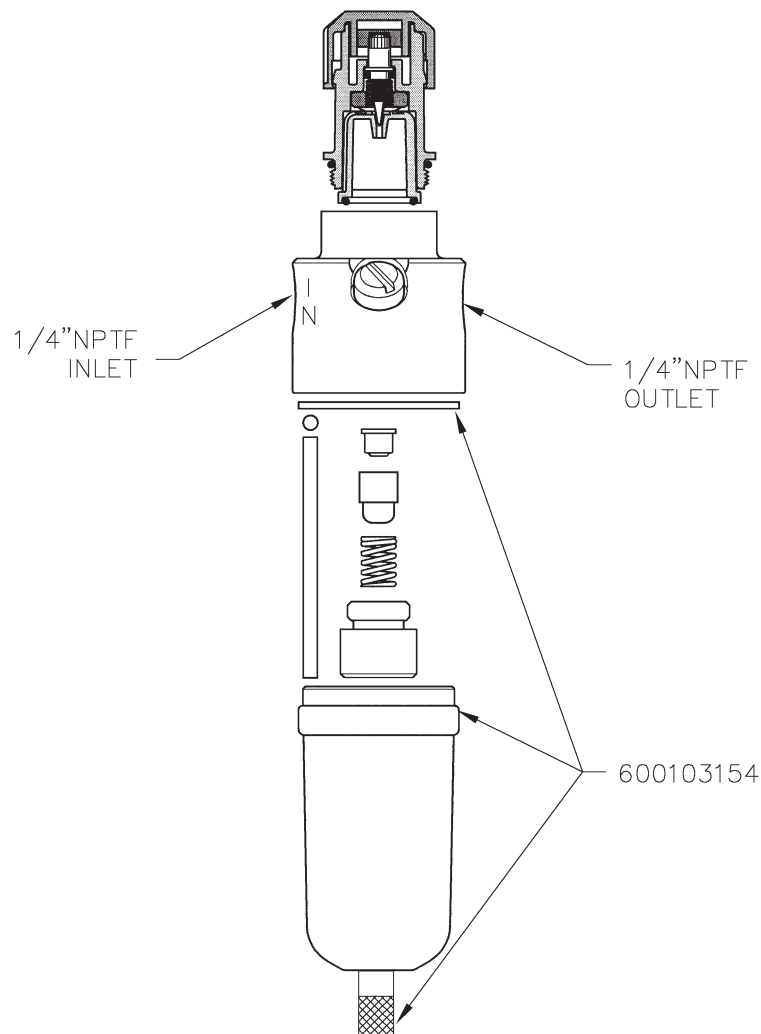

! WARNING

Never use lubricator on air supplied by A compressor lubricated with oil containing phosphate esters or glycols.

INSTALLATION

Install so air flow is in the direction of arrow stamped on back of body. Before installing, blow out lines to remove any foreign matter. If pipe compound is used, apply to male threads only and using just enough to make tight joints.

LUBRICATORS - install with bowl in vertical position. To fill, remove either of the two fill plugs and fill bowl to 1/4" of the top.

LUBRICANT - for all normal conditions, use a high quality sae no. 10 (s.u.v. 150-200 sec @ 100° f). Other lubricants specified by maker of the equipment to be lubricated may be used if not heavier than sae no. 30 (s.u.v. 575 sec. @ 100° f).

COMBINATION UNITS - are factory assembled for left-to-right flow. If right-to-left flow is required, the gauge position can be reversed by turning regulator so that its adjusting screw is facing down.

ADJUSTMENT

LUBRICATORS - turn on air supply and adjust regulator to desired pressure, start equipment and note oil drop rate through sight glass. If more lubrication is required, turn adjusting screw clockwise and counter-clockwise if less lubricant is needed. As a start, 5-10 drops per minute is usually adequate - correct lubrication is a matter of experience. To check lubrication of the equipment, hold thumbnail or a mirror near the exhaust port; a slight film of oil should be deposited at each exhaust cycle. A heavy film indicates over-lubrication and the drops per minute should be reduced.

NOTE: DO NOT TURN ADJUSTING SCREW OUT MORE THAN 1-1/2 TURNS COUNTER-CLOCKWISE FROM THE CLOSED POSITION.

MAINTENANCE

To obtain best efficiency and longest periods of trouble-free operation, the air supply must be kept clean and only clean oil for lubrication used. As dirt is the most common cause of erratic regulator operation and lubricator malfunctioning, only a few parts require an occasional replacement. Most troubles can be cured by a thorough and careful cleaning procedure. To clean, it is not necessary to remove unit from the line.

TO CLEAN LUBRICATOR

- (1) shut off air supply and unscrew bowl.
- (2) using a pair of tweezers or similar instrument, remove filter. Apply compressed air to the lower end of the dip tube to make sure the oil delivery system is free and clear. Insert a new filter.
- (3.) Remove the valve holder and the disc holder and spring. Wash any parts requiring cleaning with denatured alcohol. Be sure that the disc holder moves freely within the valve holder prior to assembly. Re-assemble the valve holder to body. Re-assemble the bowl, be sure it seats snugly against gasket.
- (4.) Fill with proper oil within 1/4" of the top of the bowl, turn air on, start equipment and set for correct lubrication as instructed under "adjustment".

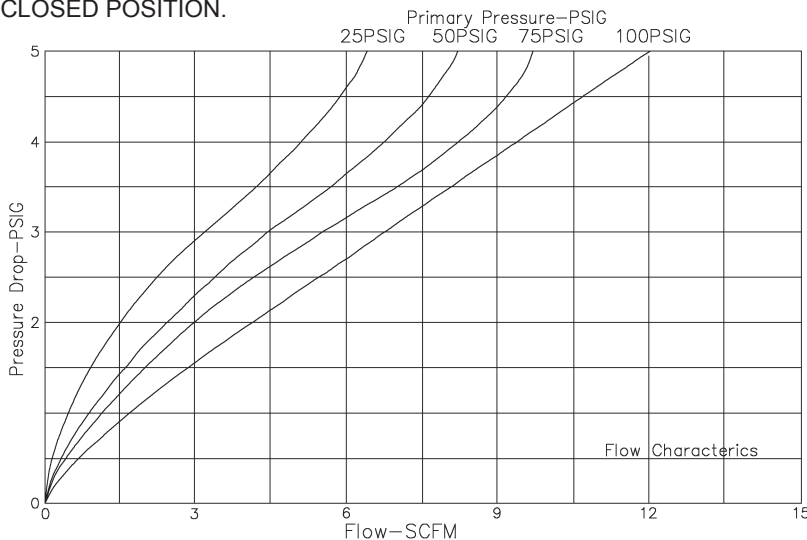

Retain This Information For Future Reference When Ordering Replacement Parts, List: Part Number, Description, Model Number, And Series Letter. Lincoln St. Louis Provides A Distributor Network That Stocks Equipment And Replacement Parts. A List Of Authorized Service Departments Will Be Furnished Upon Request.

Americas:
One Lincoln Way
St. Louis, MO 63120-1578
USA
Phone +1.314.679.4200
Fax +1.800.424.5359

Europe/Africa:
Heinrich-Hertz-Str 2-8
D-69183 Walldorf
Germany
Phone +49.6227.33.0
Fax +49.6227.33.259

Asia/Pacific:
51 Changi Business Park
Central 2
#09-06 The Signature
Singapore 486066
Phone +65.6588.0188
Fax +65.6588.3438

© Copyright 2007
Printed in USA

Web site:
www.lincolnindustrial.com