

602212 - 3/4" PORTS
602216 - 1" PORTS

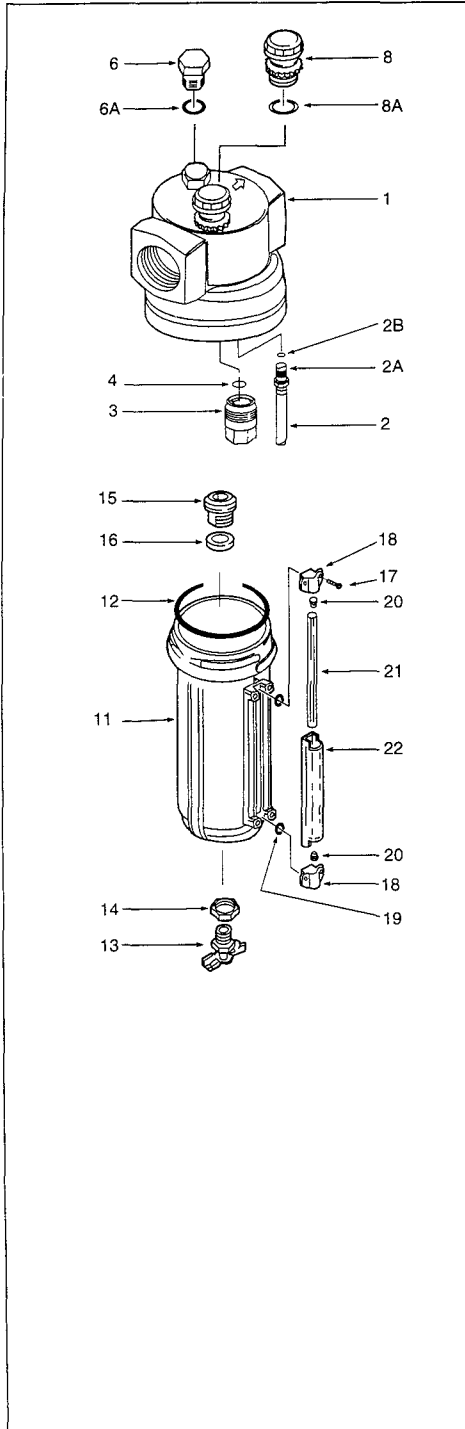

TECHNICAL DATA

Fluid: Compressed air
Maximum pressure: 250 psig (17 bar)
Operating temperature: 0° to +175°F (-20° to +79°C)*

* Air supply must be dry enough to avoid ice formation at temperatures below +35°F (+2°C).

Main ports: 3/4" PTF or 1" PTF
Start point (i.e., minimum flow required for lubricator operation): 8 scfm (3.8 dm³/s) at 90 psig (6.3 bar) inlet pressure

Approximate flow at 100 psig (6.3 bar) inlet pressure and 5 psid (0.3 bar) pressure drop:

3/4" ports: 160 scfm (76 dm³/s)
1" ports: 275 scfm (130 dm³/s)

Nominal reservoir size: 1 quart (0.95 liter)

Materials:

Body: Aluminum
Reservoir: Aluminum
Liquid level indicator lens: Pyrex
Sight feed dome: Transparent nylon
Elastomers: Neoprene and nitrile

REPLACEMENT ITEMS

Service kit (4, 6A, 8A, 12, 16)247891
Liquid level lens kit (12, 17, 19, 20, 21, 22).....247870
Sight feed dome (8, 8A)247933

INSTALLATION

1. Install lubricator vertically in air line -
 - downstream of filters and regulators,
 - upstream of cycling valves,
 - with air flow in direction of arrow on body,
 - as close as possible to the device being lubricated.
2. Connect piping to proper ports using pipe thread sealant on male threads only. Do not allow sealant to enter interior of unit.
3. Fill reservoir with a good quality, light, misting type oil for compressed air tools. Oil level must always be visible in lens (21) **DO NOT OVERFILL.**
4. Turn reservoir fully clockwise into body before pressurizing.

REFILL RESERVOIR WITH OIL

Shut off inlet pressure and reduce pressure in reservoir to zero. Remove fill plug (6), add oil, and reinstall fill plug. **Do not remove the fill plug when the reservoir is pressurized, as oil will blow out the fill plug hole.**

ADJUSTMENT

1. Turn on system pressure.
2. Adjust lubricator drip rate only when there is a constant rate of air flow thru the lubricator. Monitor drip rate thru sight feed dome (8).
3. Determine the average rate of flow thru the lubricator. Turn adjusting knob (8) to obtain the recommended drops per minute. See **Drip Rate Chart**. Turn knob counterclockwise to increase and clockwise to decrease the drip rate. Push red locking on adjusting knob down to lock drip rate setting. Pull locking up to release.

4. Monitor the device being lubricated for a few days following initial adjustment. Adjust the drip rate if the oil delivery at the device appears either excessive or low.

DRIP RATE CHART

3/4" Ports		1" Ports	
Flow scfm (dm ³ /s)	Drops per Minute	Flow scfm (dm ³ /s)	Drops per Minute
10 (5)	8	10 (5)	10
20 (9)	10	25 (12)	14
40 (19)	12	50 (24)	21
60 (28)	14	75 (35)	28
80 (38)	16	100 (47)	35
100 (47)	18	125 (59)	41
120 (57)	20	150 (71)	47
140 (66)	22	175 (83)	54
160 (76)	24	200 (94)	60
		225 (106)	66
		250 (118)	73
		275 (130)	80

DISASSEMBLY

1. Shut off inlet pressure. Reduce pressure in inlet and outlet lines to zero. Loosen fill plug (6)
2. Remove reservoir by turning counterclockwise
3. Disassemble in general accordance with the item numbers on exploded view

CLEANING

1. Clean all parts using warm water and soap
2. Rinse and dry parts. Blow out internal passages in body with clean, dry compressed air.
3. Inspect parts. Replace parts found to be damaged.

ASSEMBLY

1. Lubricate seals and o-rings with o-ring grease
2. Assemble sight glass components (17 thru 22) to reservoir. Apply a slight clamping force to upper and lower sight glass brackets (18) to pull brackets together, then tighten screws (17).
3. Assemble lubricator as shown on exploded view.
4. Turn reservoir (11) into body until arrowhead is in line with, or to the right of, the arrowhead on body.
5. Torque Table

	Inch-Pounds (N-m)
14 (nut)	20 to 25 (2.3 to 2.8)
3 (fog generator)	30 to 35 (3.4 to 4.0)
8 (sight feed dome)	30 to 35 (3.4 to 4.0)
17 (screw)	8 to 10 (0.9 to 1.1)

WARNING

These products are intended for use in industrial compressed air systems only. Do not use these products where pressures and temperatures can exceed those listed under **Technical Data**. In lubrication applications some oil mist may escape from the point of use to the surrounding atmosphere. Users are referred to OSHA safety and health standards for limiting oil mist contamination and utilization of protecting equipment. Do not use these products with fluids other than air, for nonindustrial applications, or for life-support systems.