

**602112 - 3/4" PORTS, MANUAL DRAIN**  
**602113 - 3/4" PORTS, AUTOMATIC DRAIN**  
**602116 - 1" PORTS, MANUAL DRAIN**  
**602117 - 1" PORTS, AUTOMATIC DRAIN**

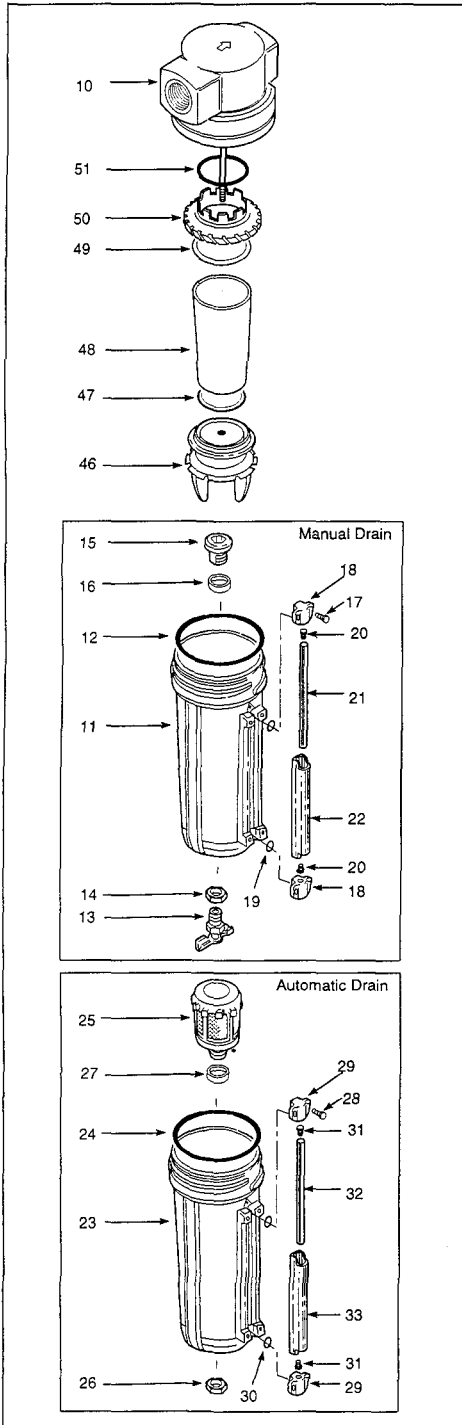

**TECHNICAL DATA**

Fluid: Compressed air  
Maximum pressure: 250 psig (17 bar)  
Operating temperature: \* 0 to +175°F (-20° to +79°C)  
\* Air supply must be dry enough to avoid ice formation at temperatures below +35°F (+2°C).

Main ports: 3/4" PTF or 1" PTF  
Filter element rating: 40µm

**Materials:**

Body: Aluminum  
Bowl: Aluminum  
Liquid level indicator lens: Pyrex  
Element: Sintered bronze  
Elastomers: Neoprene and nitrile

**REPLACEMENT ITEMS**

Liquid level lens kit (12, 17, 19, 20,  
21, 22, 24, 28, 30, 31, 32, 33) .....247870  
Filter element, 40µm .....247888  
Service kit (12, 16, 24, 27, 47, 49, 51) ...247889  
Drain, automatic (25, 26, 27) .....247932

**INSTALLATION**

1. Install filter vertically in air line -
  - upstream of regulators, lubricators, and cycling valves,
  - with air flow in direction of arrow on body,
  - as close as possible to the air supply when used as a main line filter,
  - as close as possible to the device being serviced when used as a final filter.
2. Connect piping to proper ports using pipe thread sealant on male threads only. Do not allow sealant to enter interior of unit.
3. Turn bowl fully clockwise into body before pressurizing.
4. Connect flexible tube with 0.125" (3mm) minimum I.D. to automatic drain connection (1/8" NPTF). Avoid restrictions in the tube.

**SERVICING**

1. Open manual drain (13) to expel accumulated liquids. Keep liquids below baffle (46).
2. Depress pin inside automatic drain outlet to operate drain manually.
3. Clean or replace filter element (48) when dirty.

**DISASSEMBLY**

1. Shut off inlet pressure. Reduce pressure in inlet and outlet lines to zero.
2. Remove bowl by turning counterclockwise.
3. Disassemble in general accordance with the item numbers on exploded view. Automatic drain (25) is not repairable. Replace if it malfunctions.

**CLEANING**

1. Clean all parts with warm water and soap.
2. Rinse and dry parts. Blow out internal passages in body (10) with clean, dry compressed air. Blow air through filter element (48) from inside to outside to dislodge surface contaminants.
3. Inspect parts. Replace parts found to be damaged.

**ASSEMBLY**

1. Lubricate o-rings with o-ring grease.
2. Assemble sight glass components (17 thru 22 or 28 thru 33) to bowl. Apply a slight clamping force to upper and lower sight glass brackets (18 or 29) to pull brackets together, then tighten screws (17 or 28).
3. Assemble the filter as shown on the exploded view. Place o-ring (51) on louver (50), then press into place in body (10). Screw baffle (46) onto center post until contact is made with the filter element (48), then tighten an additional 1/4 turn.
4. Turn bowl into body until arrowhead is in line with, or to the right of, the arrowhead on body.
5. Torque Table
 

Inch-Pounds (N-m)	Inch-Pounds (N-m)
13 (drain)	15 to 20 (1.7 to 2.3)
14 (nut)	20 to 25 (2.3 to 2.8)
17, 28 (screw)	8 to 10 (0.9 to 1.1)

**CAUTION**

Water vapor will pass through these units and could condense into liquid form downstream as air temperature drops. Install an air dryer if water condensation could have a detrimental effect on the application.

**WARNING**

These products are intended for use in industrial compressed air systems only. Do not use these products where pressures and temperatures can exceed those listed under **Technical Data**.

Do not use these products with fluids other than air, for nonindustrial applications, or for life-support systems.